



Long Range Capital Committee

Wednesday, September 28, 2022 2:00PM
40 McMaster Street, Ballston Spa, NY

Chair: Theodore Kusnierz

Members:

Jonathan Schopf
Phil Barret
Matt Veitch
John Lant
Andrew Jarosh
Steve Bulger

- I. Welcome and Attendance
- II. Approval of the minutes of the September 30, 2021 meeting.
- III. Charge of the Committee
- IV. Status of the 2022 Capital Register
- V. 2023 Capital Requests
- VI. Approval of the 2023 Five Year Capital Improvement Plan
- VII. Other Business
- VIII. Adjournment



OFFICE OF THE
COUNTY ADMINISTRATOR
OF SARATOGA COUNTY

40 MCMASTER STREET
BALLSTON SPA, NEW YORK 12020
(518) 884-4742
WWW.SARATOGACOUNTYNY.GOV

STEVE BULGER
COUNTY ADMINISTRATOR

RIDGE HARRIS
DEPUTY COUNTY
ADMINISTRATOR

STEPHANIE HODGSON
BUDGET DIRECTOR

MATTHEW ROSE
MANAGEMENT ANALYST

AUDRA M. HEDDEN
EXECUTIVE SECRETARY

September 27, 2022

Chairman Kusnierz and Members of the Long-Range Capital Planning Committee,

As part of the County's annual budget process, Departments are directed to identify items and projects that meet the criteria for the Capital Plan as outlined in the Operating Budget Procedure policy. Enclosed is a list of all the items that were requested along with the recommendations from my office.

This plan makes necessary investments in equipment and facilities to ensure that we can continue to provide quality services to our residents.

The recommendations to not fund requests are based on a variety of factors such as, duplication of equipment, ability to extend useful life of current equipment beyond 2023, and the information presented by the departments.

Of the equipment and projects recommended as part of this plan, the funding is already included in the draft tentative budget that is still being finalized. Any additions to the recommended expenses will require an appropriation from Fund Balance.

As has been the case for many years, the County's highway program is the most robust portion of the annual Capital Plan. It's an important and critical service that we provide as a county to ensure safe roadways and bridges in all weather conditions. We'll continue to cycle out aging equipment while maintaining the integrity of our bridges and adhering to our road repaving cycle.

With the announcement of the \$27 million grant from New York State for the County Airport, we have a unique opportunity to reimagine one of the many gateways to the county. Within this Capital Plan is \$20 million for the airport project. These funds, which are reimbursable up to \$27 million, will be housed in the Capital Facilities Reserve Fund established by the Board of Supervisors earlier this year. The remaining funds needed to complete the project will be allocated through the 2024 annual budget planning process next year.

I am pleased to provide these recommendations for what I believe is a robust plan that meets the needs of our departments to provide the services that our residents have come to expect and deserve.

Sincerely,

Steve Bulger

2023 Saratoga County Capital Plan

<u>Project</u>	<u>Department Request</u>	<u>Administration Suggestion</u>
Highway Reconstruction		
9A (River Street Bridge) .06 miles	\$21,600	\$21,600
13B (Fayville Road) 3.35 miles	\$884,800	\$884,800
14D (Fishhouse Road) 2.44 miles	\$623,700	\$0
24B (Spier Falls Road) 2.60 miles	\$622,800	\$622,800
24D (Spier Falls Road) 1.19 miles	\$309,900	\$309,900
34A (Northern Pines Road) 2.29 miles	\$613,900	\$613,900
36B (Wilton/Greenfield Road) 2.76 miles	\$714,100	\$714,100
51 B,C (Charlton Road) 2.47 miles	\$639,200	\$639,200
59C (Middle Line Road) 2.0 miles	\$517,000	\$517,000
CR 66A (Dyer Switch Road) .88 miles	\$228,300	\$228,300
<u>339A (Lake Hill Road) .16 miles</u>	\$47,200	\$47,200
	\$5,222,500	\$4,598,800
Highway Structures		
Hans Creek Road Bridge over Hans Creek	\$572,000	\$572,000
North Shore Road over Beecher Creek	\$1,485,000	\$1,485,000
Nelson Ave over Trib. Of Saratoga Lake	\$70,000	\$70,000
Rowland Street over Rowland Hollow Creek	\$528,000	\$528,000
Coons Crossing Road over Anthony Kill - Replacement	\$1,313,000	\$1,313,000
<u>Lasher Road over Mourning Kill - Rehabilitation</u>	\$1,079,800	\$1,079,800
	\$5,047,800	\$5,047,800
Highway Equipment:		
3 Large Dump/Plow Trucks	\$900,000	\$600,000
1 Backhoe	\$221,000	\$221,000
1 Vacuum/Jet Truck	\$640,000	\$640,000
4 Pickup Trucks	\$286,000	\$143,000
1 F250 Truck with Plow	\$67,000	\$67,000

1 Chip Truck	\$247,250	\$247,250
2 Carry-Alls	\$154,000	\$77,000
1 Single Axle Dump	\$160,650	\$0
1 Rack Truck	\$72,500	\$0
1 Patch Roller	\$70,000	\$70,000
1 Mini Excavator	\$172,000	\$0
1 Tractor with Mower	\$125,700	\$125,700
2 Variable Message Signs	\$36,500	\$0
3 Tilt Deck Trailers	\$45,300	\$30,100
1 Ventrack 4520Z Tractor	\$60,000	\$0
1 Dump Trailer	\$14,000	\$0
1 Enclosed Trailer	\$15,000	\$0
1 Asphalt Reclaimer	\$49,000	\$49,000
1 Tractor Mower (Airport)	\$178,200	\$178,200
1 14 ton asphalt roller	\$176,400	\$0
1 Salt Conveyor	\$149,800	\$0
1 Turf Mower	\$18,900	\$0
1 Loader	\$441,000	\$0
1 Wood Chipper	\$110,000	\$0
1 Ford Transit Work Van	\$58,000	\$0
1 Passenger Mini Van	\$38,000	\$0
1 Stump Grinder	\$60,500	\$0
1 Water Truck	\$222,000	\$0

\$4,788,700

\$2,448,250

Airport

Rehabilitation Runway 5-23 (Design)	\$225,000	\$225,000
Rehabilitation Western Itinerant Apron (Design)	\$180,000	\$180,000
Obstruction Removal Acquire Easements-Phase 1 Properties	\$400,000	\$400,000
	\$805,000	\$805,000

Major Building Equipment/Project Program:

Bldg 2,3, & 4 Circulator pumps	\$250,000	\$0
Bldg 4 Heat Pumps	\$100,000	\$0
Public Works Fuel Island Pumps	\$450,000	\$450,000
Animal Shelter HVAC	\$680,000	\$680,000
	\$1,480,000	\$1,130,000

Building #5 Roof Replacement

	\$1,045,000	\$0
--	-------------	-----

Parking Lot Reconstruction:

Cty Farm Rd. Access Rd. CR45 to Fuel Island	\$75,000	\$75,000
---	----------	----------

Animal Shelter:

Metal Roof on Crematory Building	\$25,000	\$25,000
Kennel Pressure Washer System	\$30,000	\$30,000
	\$55,000	\$55,000

Sheriff:

Full Body Scanner	\$140,000	\$0
Walk-through Metal Detector	\$10,000	\$10,000
Corrections - Various	\$1,275,000	\$1,000,000
	\$1,425,000	\$1,010,000

County Clerk:

Records Mgmt Shelving	\$112,246	\$0
-----------------------	-----------	-----

Public Health

2 Vehicles for Environmental Health	\$60,000	\$60,000
-------------------------------------	----------	----------

Emergency Services:

HZMAT vehicle	\$650,000	\$0
Fire Training pavilion	\$25,000	\$0
Burn Building	\$975,000	\$0
	\$1,650,000	\$0

Airport Welcome Center	\$20,000,000	\$20,000,000
-------------------------------	---------------------	---------------------

Total Capital Projects	\$41,766,246	\$35,229,850
-------------------------------	---------------------	---------------------

SARATOGA COUNTY DEPARTMENT OF PUBLIC WORKS
3654 GALWAY ROAD
BALLSTON SPA, NEW YORK 12020
TELEPHONE: 518-885-2235

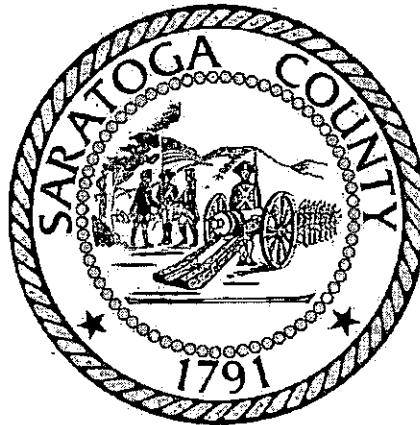

**2023 – 2027
CAPITAL PLAN**

**CHAD M. COOKE, P.E.
COMMISSIONER**

**THOMAS A. SPEZIALE
DEPUTY COMMISSIONER**

JULY 2022

INDEX

DEPARTMENT OF PUBLIC WORKS

2023 - 2027 CAPITAL PROGRAM

<u>CAPITAL PROJECTS</u>	<u>PAGES</u>
Highway Reconstruction Program	1 - 6
Highway Structures Program	7 - 18
Highway Equipment Program	19 - 48
Airport Improvement Program	49 - 52
Building Equipment/Project Program	53 - 57
Roof Replacement/Repair Program	58 - 59
Parking Lot Reconstruction Program	60 - 61

PROJECT NO.	_____
PRIORITY NO.	_____

20 23 CAPITAL PLAN
INDIVIDUAL CAPITAL PROJECT REQUEST AND ESTIMATE OF COST

1. Department Public Works 2.Division Highways
 3. Project Title Highway Reconstruction Program
 4. Location County Highway System
 5. Description Scarify existing pavement, reclaim and recycle existing pavement, install new gravel base, install new drainage pipes, and re-pave with new asphalt pavement or surface treat with stone and oil. County to construct standard 10 ft. lanes with paved shoulders.
 6. Purpose and Justification The County maintains 365 centerline miles of highway. With the increase in traffic volumes, we must reconstruct approximately 20 miles of highway per year for an 18 year life cycle. The proposed 2023 plan will reconstruct 20.20 miles of County highway.

7. Status of Plans: (check)

<input type="checkbox"/> Plans not Needed	<input type="checkbox"/> Surveys completed	<input type="checkbox"/> Sketch plans completed
<input type="checkbox"/> Nothing done on plans	<input type="checkbox"/> Work on Plans scheduled	<input type="checkbox"/> Detail plans in preparation
<input checked="" type="checkbox"/> Preliminary estimate received	<input type="checkbox"/> Sketch plans in preparation	<input type="checkbox"/> Detail plans completed

8. Estimated Cost:

Engineering	_____
Site Acquisition	_____
Construction	\$ 5,222,500
Other ()	_____
TOTAL	\$ 5,222,500

11. Proposed Method of Financing:

Obligations	\$ _____
Current Revenues	_____
Special Assessments	_____
User Charges	_____
State Aid *	\$ 5,221,919
Federal Aid	_____
Reserves	\$ 581
Other	_____
TOTAL	\$ 5,222,500

9. Proposed Method of Construction:
 Contract Municipal Employees

* Estimated CHIPS, PaveNY, EWR and P.O.P

10. Estimated Project Expenditures by Years:

20 23	\$ 5,222,500
20 24	\$ -
20 25	\$ -
20 26	\$ -
20 27	\$ -
20 _____	_____
20 _____	_____
Later _____	_____

12. If Obligations are to be issued, State:
 Type _____
 Period of Years from _____ to _____

13. Effect the Project will have on Operating and Maintenance Expenditures for first three years of operation; (plus or minus)

20 _____	_____
20 _____	_____
20 _____	_____

Submitted By: Chad M. Cooke P.E., Commissioner of Public Works Date July 2022
 Long Range Capital Planning _____ Date _____
 Governing Board Action _____ Date _____

Note: Furnish as much of the information requested as is available at the time of preparation. Attach maps and other supporting data that will aid in evaluating the project.

2023-2027 HIGHWAY RECONSTRUCTION PROGRAM

2023

COUNTY ROAD	TOWN	SECTION	MILES	TOTAL (Mat'ls, Rental & Sub-contractors)
9 A (River Street Bridge)	Corinth	SR 9N to Bridge	0.06	\$21,600
13 B (Fayette Road)	Providence	Potter Hollow to Hans Creek	3.35	\$884,800
14 D (Fishhouse Road)	Providence	Crannel Road to Fulton County Line	2.44	\$623,700
24 B (Spier Falls Rd)	Corinth / Moreau	CR 25 to Entrance to Power Station	2.60	\$622,800
24 D (Spier Falls Rd)	Moreau	Sherman Island Boat Launch to East Side of Mountain	1.19	\$309,900
34 A (Northern Pines Road)	Wilton	SR 9 to Traver Road	2.29	\$613,900
36 B (Wilton/Greenfield Road)	Greenfield	Brigham Rd to US 9	2.76	\$714,100
51 B,C (Charlton Road)	Charlton	Ballston Town Line to CR 52	2.47	\$639,200
59 C (Middle Line Road)	Milton	SR 67 to CR 45	2.00	\$517,000
CR 66 A (Dyer Switch Road)	Saratoga Springs	NY 9P to CR 65	0.88	\$228,300
339 A (Lake Hill Road)	Ballston	CR 110 to SR 50	0.16	\$47,200
		TOTALS	20.20	\$5,222,500

2023-2027 HIGHWAY RECONSTRUCTION PROGRAM

2024

COUNTY ROAD	TOWN	SECTION	MILES	TOTAL (Mat'l's, Rental & Sub-contractors)
4 C,D (North Shore Road)	Edinburg/Day	Lakeland Road to Glasshouse Road	3.51	\$900,400
7 C (South Shore Road)	Edinburg	CR 98 to Gordon Creek	2.42	\$620,800
45 D (Ballston Road)	Galway	CR 52 to Armer Road	1.53	\$392,500
56 B (Hop City Road)	Ballston	CR 51 to NYS 67	3.25	\$833,700
71 B (Cedar Bluff Road)	Saratoga	SR 32 to Sweet Road	1.59	\$407,900
96 A (Middletown Road)	Waterford	Village Line to CR 97	2.80	\$718,300
109 B, C Farm to Market Road	Halfmoon	US 9 to SR 146	4.10	\$1,051,800
		TOTALS	19.20	\$4,925,400

2023-2027 HIGHWAY RECONSTRUCTION PROGRAM

2025

COUNTY ROAD	TOWN	SECTION	MILES	TOTAL (Mat'ls, Rental & Sub-contractors)
4 A (North Shore Road)	Edinburg	County Line to CR 5 & CR 98	1.61	\$421,300
4 E (North Shore Road)	Day	Glasshouse Rd. to Hadley Hill Rd.	2.42	\$633,200
10 C (Corinth West Mtn. Road)	Corinth	Stewart Dam Rd. to Davignon Rd.	3.54	\$926,300
13 A (Fayette Road)	Providence	CR 16 to Potter Hollow Road	2.41	\$630,600
14 B (Crooked Street)	Galway	Camp Road to SR 29	1.83	\$478,800
23 A (Brook Road)	Saratoga Springs	SR 29 to SR 9N	1.02	\$266,900
69 A (Coveville Road)	Saratoga	SR 32 to US 4	2.42	\$633,200
90 A (Vischer Ferry Road)	Clifton Park	CR 92 to CR 91	2.39	\$625,400
110 A (Blue Barns Road)	Ballston/Clifton Park	SR 146 to Kingsley Road	2.73	\$714,300
		TOTALS	20.37	\$5,330,000

2023-2027 HIGHWAY RECONSTRUCTION PROGRAM

2026

COUNTY ROAD	TOWN	SECTION	MILES	TOTAL (Mat'ls, Rental & Sub-contractors)
21 B (Middle Grove Road)	Greenfield	Kayaderosseras Creek to King Road	2.38	\$635,200
39 A (King Road)	Wilton/Northumberland	Homestead Road to SR 50	2.66	\$709,900
45 I,J (North Line Road)	Milton	CR 50 to CR 63	1.91	\$509,800
51 A (Charlton Road)	Charlton	NYS 147 to CR 52	2.68	\$715,300
55 A (Sweetman Road)	Charlton	CR 51 to SR 67	2.88	\$768,700
56 A (Scotch Bush Road)	Ballston	County Line to CR 51	2.60	\$693,900
60 A,B (Brookline Road)	Ballston	CR 59 to SR 67	1.51	\$403,000
92 B (Crescent Rd)	Clifton Park	Moe Road to 187	1.17	\$312,300
101 A (Corinth Mtn. Road)	Wilton	SR 9 to Corinth Mtn. Road	0.52	\$138,800
108 A (Dunning St)	Malta	SR 9 to Hermes Road	0.91	\$242,900
		TOTALS	19.22	\$5,129,800

2023-2027 HIGHWAY RECONSTRUCTION PROGRAM

2027

COUNTY ROAD	TOWN	SECTION	MILES	TOTAL (Mat'ls, Rental & Sub-contractors)
4 I (North Shore Rd)	Hadley	CR 7 to Warren County Line	2.88	\$784,000
21 A (Middle Grove Road)	Galway / Providence /Greenfield	SR 29 to Kayderosseras Creek	3.27	\$890,200
39 B (King Rd)	Northumberland	Homestead Rd to SR 32	2.18	\$593,500
52 G (Jockey Street)	Galway	Old Mill Rd to SR 29	2.77	\$754,100
70 B (Wayville Rd)	Saratoga	CR 71 to CR 67	1.90	\$517,200
75 C (Mechanicville- Stillwater Road)	Stillwater	CR 76 to NYS 423	1.23	\$334,800
80 A (Schauber Rd.)	Clifton Park/Ballston	NYS Rte 146A to Lake Rd	2.00	\$544,500
80 C (Round Lake Rd.)	Malta	CR 82 to I87 Southbound Ramp	1.13	\$307,600
97 A (Fonda Rd)	Waterford	Waterford Village Line to CR 96	2.60	\$707,800
		TOTALS	19.96	\$5,433,700

ROAD	LOCALLY PROGRAMMED STRUCTURES	TOWN	B.I.N.	L.I.N.	PHASE *	METHOD OF CONSTRUCTION **	TOTAL EST. COUNTY COST
Town	Hans Creek Road Bridge over Hans Creek (E-2022)	Providence	2202830	177.00	C	C	\$572,000
CR 4	North Shore Road over Beecher Creek (E-2022)	Edinburg	3304790	180.00	C	C	\$1,485,000
CR 64	Nelson Ave. over Trib. of Saratoga Lake (C-2024)	Malta	N/A	279.20	E, I	C	\$70,000
CR 47	Rowland Street over Rowland Hollow Creek (E - 2022)	Milton	N/A	319.60	C	C	\$528,000
SUBTOTAL							\$2,655,000



HIGHWAY STRUCTURES PROGRAM
SARATOGA COUNTY 2023 TO 2027
YEAR 2023

ROAD	FEDERAL/STATE PROGRAMMED STRUCTURES (County Administered, U.N.O.*)	TOWN	B.I.N.	L.I.N.	PHASE *	METHOD OF CONSTRUCTION **	COUNTY SHARE (5%)	TOTAL PHASE COST	ANTICIPATED REVENUE FEDERAL (80%) + STATE (15%), UNO
Town	Coons Crossing Road over Anthony Kill Replacement F/S, CDTC, SA # 317, PIN 1761.78, (E- 2021)	Halfmoon	2202750	10.00	ROW, C, I	C	\$85,650	\$1,313,000	\$1,247,350
Town	Lasher Road over Mourning Kill Rehabilitation F/S, CDTC, SA # 318, PIN 1761.79, (E- 2021)	Ballston	3304700	104.00	ROW, C, I	C	\$53,990	\$1,079,800	\$1,025,810
SUBTOTALS							\$119,640	\$2,392,800	\$2,273,160
TOTALS							\$2,774,640	\$5,047,800	\$2,273,160

* E = Engineering, R.O.W. = Right of Way, C = Construction, I = Inspection, U.N.O. = Unless Noted Otherwise

** C = Contract, M = Municipal Employees

F/S = Federal & State Aid Project, 80/15/5

ROAD	LOCALLY PROGRAMMED STRUCTURES	TOWN	B.I.N.	L.I.N.	PHASE *	METHOD OF CONSTRUCTION **	TOTAL EST. COUNTY COST
CR 64	Nelson Ave.Ext. over Kayaderosseras Creek (C-2025)	Malta	3304450	71.00	E, I	C	\$96,800
City	Viall Avenue over Anthony Kill (C-2025)	Mechanicville	2202970	207.00	E, ROW, I	C	\$380,600
CR 91	Grooms Road over Stony Creek (C-2025)	Clifton Park	N/A	266.00	E, I	C	\$183,700
CR 64	Nelson Ave. over Trib of Saratoga Lake (E-2023)	Malta	N/A	279.20	C	C	\$500,000
CR 80	Maltaville Road over Trib. to Round Lake (C-2025)	Malta	N/A	279.90	E, I	C	\$210,000
CR 33	Ballard Road over Snook Kill (C-2026)	Wilton	2202870	290.00	E, ROW, I	C	\$756,800
Town	Tiffault Road over Mourning Kill (C-2027)	Ballston	3304670	306.00	E, ROW, I	C	\$547,800
SUBTOTAL:							\$2,675,700

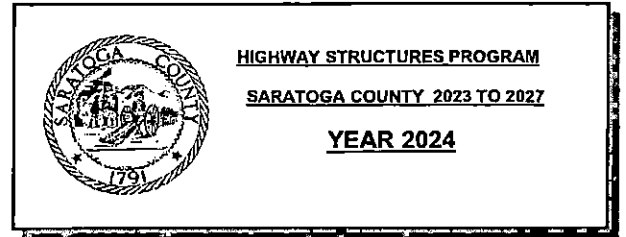

ROAD	FEDERAL/STATE PROGRAMMED STRUCTURES (County Administered, U.N.O.*)	TOWN	B.I.N.	L.I.N.	PHASE *	METHOD OF CONSTRUCTION **	COUNTY SHARE (5%)	TOTAL PHASE COST	ANTICIPATED REVENUE FEDERAL (80%) + STATE (15%), UNO
CR 24	Spler Falls Road over Hudson River Trib. F/S, A/GFTC, SAR # 130, PIN 1761.41, (E-2022)	Moreau	N/A	251.00	ROW, C, I	C	\$62,915	\$1,258,300	\$1,195,385
SUBTOTALS:							\$62,915	\$1,258,300	\$1,195,385
TOTALS:							\$2,738,615	\$3,934,000	\$1,195,385

* E = Engineering, R.O.W. = Right of Way, C = Construction, I = Inspection, U.N.O. = Unless Noted Otherwise
** C = Contract, M = Municipal Employees
F/S = Federal & State Aid Project, 80/15/5

ROAD	LOCALLY PROGRAMMED STRUCTURES	TOWN	B.I.N.	L.I.N.	PHASE *	METHOD OF CONSTRUCTION **	TOTAL EST. COUNTY COST
CR 64	Nelson Ave.Ext. over Kayaderosseras Creek (E-2024)	Malta	3304450	71.00	C	C	\$478,500
Town	Corinth Bridge over Sacandaga River (Bow Bridge) - Rail Replacement	Hadley	2202740	142.00	C	M	\$55,000
CR 4	North Shore Road over Sand Creek (C-2027)	Day	3304780	182.00	E	C	\$75,000
City	Viall Avenue over Anthony Kill (E-2024)	Mechanicville	2202970	207.00	C	C	\$1,804,000
CR 91	Grooms Road over Stony Creek (E-2024)	Clifton Park	N/A	266.00	C	C	\$594,000
CR 80	Maltaville Road over Trib. to Round Lake (E-2024)	Malta	N/A	279.90	C	C	\$682,000
SUBTOTAL							\$3,688,500

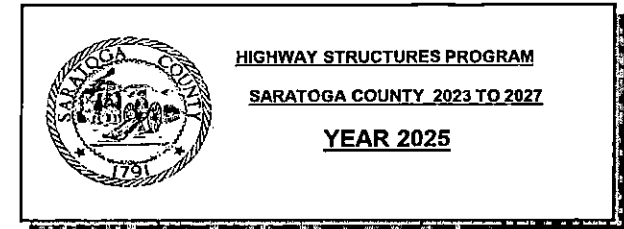

ROAD	FEDERAL/STATE PROGRAMMED STRUCTURES (County Administered, U.N.O.*)	TOWN	B.I.N.	L.I.N.	PHASE *	METHOD OF CONSTRUCTION **	COUNTY SHARE (%)	TOTAL PHASE COST	ANTICIPATED REVENUE FEDERAL (80%) + STATE (15%), UNO
SUBTOTALS							\$0	\$0	\$0
TOTALS							\$3,688,500	\$3,688,500	\$0

* E = Engineering, R.O.W. = Right of Way, C = Construction, I = Inspection, U.N.O. = Unless Noted Otherwise

** C = Contract, M = Municipal Employees

ROAD	LOCALLY PROGRAMMED STRUCTURES	TOWN	B.I.N.	L.I.N.	PHASE *	METHOD OF CONSTRUCTION **	TOTAL EST. COUNTY COST
Town	Tabor Road over Dwaas Kill (C-2028)	Halfmoon	2202760	11.00	E,ROW,I	C	\$1,254,000
Town	Burgoyne Road over Fish Creek (C-2027)	Saratoga	3304430	34.00	E, I	C	\$77,000
CR 63	Staffords Bridge Road over Sucker Brook (C-2027)	Saratoga	N/A	230.00	E,I	C	\$55,000
CR 33	Ballard Road over Snook Kill (E-2024)	Willton	2202870	290.00	C	C	\$2,310,000
CR 14	Crooked Street over Lake Butterfield Inlet (C-2027)	Galway	N/A	360.00	E,I	C	\$170,500
SUBTOTAL							\$3,866,500



HIGHWAY STRUCTURES PROGRAM
SARATOGA COUNTY 2023 TO 2027
YEAR 2026

ROAD	FEDERAL/STATE PROGRAMMED STRUCTURES (County Administered, U.N.O.*)	TOWN	B.I.N.	L.I.N.	PHASE *	METHOD OF CONSTRUCTION **	COUNTY SHARE (5%)	TOTAL PHASE COST	ANTICIPATED REVENUE FEDERAL (80%) + STATE (15%), UNO
SUBTOTALS							\$0	\$0	\$0
TOTALS							\$3,866,500	\$3,866,500	\$0

* E = Engineering, R.O.W. = Right of Way, C = Construction, I = Inspection, U.N.O. = Unless Noted Otherwise
** C = Contract, M = Municipal Employees

ROAD	LOCALLY PROGRAMMED STRUCTURES	TOWN	B.I.N.	L.I.N.	PHASE *	METHOD OF CONSTRUCTION **	TOTAL EST. COUNTY COST
Town	Burgoyne Road over Fish Creek (E-2026)	Saratoga	3304430	34.00	C	C	\$715,000
CR 4	North Shore Road over Sand Creek (E-2025)	Day	3304780	182.00	C	C	\$350,000
CR 68	Staffords Bridge Road over Sucker Brook (E-2026)	Saratoga	N/A	230.00	C	C	\$495,000
Town	Tiffault Road over Mourning Kill (E-2024)	Ballston	3304670	308.00	C	C	\$1,375,000
CR 14	Crooked Street over Lake Butterfield Inlet (E-2026)	Galway	N/A	360.00	C	C	\$659,500
SUBTOTAL							\$3,594,500

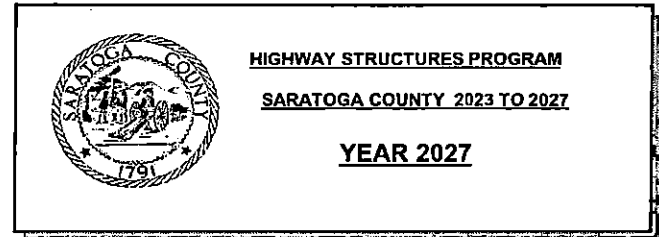

ROAD	FEDERAL/STATE PROGRAMMED STRUCTURES (County Administered, U.N.O. *)	TOWN	B.I.N.	L.I.N.	PHASE *	METHOD OF CONSTRUCTION **	COUNTY SHARE (5%)	TOTAL PHASE COST	ANTICIPATED REVENUE FEDERAL (80%) + STATE (15%), UNO
SUBTOTALS							\$0	\$0	\$0
TOTALS							\$3,594,500	\$3,594,500	\$0

* E = Engineering, R.O.W. = Right of Way, C = Construction, I = Inspection, U.N.O. = Unless Noted Otherwise
** C = Contract, M = Municipal Employees

PROJECT NO.	1
PRIORITY NO.	1

20 23 CAPITAL PLAN
INDIVIDUAL CAPITAL PROJECT REQUEST AND ESTIMATE OF COST

1. Department Public Works 2.Division Highway
 3. Project Title Replacement of the Hans Creek Bridge over Hans Creek, BIN 2202830, LIN 177.00
 4. Location Town of Providence
 5. Description Replace the structure

6. Purpose and Justification The structure is deficient. Condition Rating 4.021

7. Status of Plans: (check)

- | | | |
|--|--|---|
| <input type="checkbox"/> Plans not needed | <input type="checkbox"/> Surveys completed | <input type="checkbox"/> Sketch plans completed |
| <input type="checkbox"/> Nothing done on plans | <input type="checkbox"/> Work on Plans scheduled | <input checked="" type="checkbox"/> Detail plans in preparation |
| <input type="checkbox"/> Preliminary estimate received | <input type="checkbox"/> Sketch plans in preparation | <input type="checkbox"/> Detail plans completed |

8. Estimated Cost: (Required County Funding)

2022	Engineering	
	Site Acquisition	\$ -
	Construction	\$ 572,000
	Other (Insp.)	\$ -
	TOTAL	\$ 572,000

11. Proposed Method of Financing:

Obligations	\$ -
Current Revenues	\$ -
Special Assessments	\$ -
User Charges	\$ -
State and Federal Aid	\$ -
Reserves	\$ 572,000
Other	
TOTAL	\$ 572,000

9. Proposed Method of Construction:

- Contract Municipal Employees

10. Estimated Project Expenditures by Years:

20 23	\$ 572,000
20 24	\$ -
20 25	\$ -
20 26	\$ -
20 27	\$ -
20 _____	_____
20 _____	_____
Later _____	_____

12. If Obligations are to be issued, State:

Type _____
 Period of Years from _____ to _____

13. Effect the Project will have on Operating and Maintenance Expenditures for first three years of operation; (plus or minus)

20 _____	_____
20 _____	_____
20 _____	_____

Submitted By: Chad M. Cooke, P.E., Commisioner of Public Works Date July 2022

Long Range Capital Planning _____ Date _____

Governing Board Action _____ Date _____

Note: Furnish as much of the information requested as is available at the time of preparation. Attach maps and other supporting data that will aid in evaluating the project.

PROJECT NO.	2
PRIORITY NO.	2

20 23 CAPITAL PLAN
INDIVIDUAL CAPITAL PROJECT REQUEST AND ESTIMATE OF COST

1. Department Public Works 2.Division Highway
3. Project Title Replacement of the CR 4 (North Shore Road) Bridge over Beecher Creek, BIN 3304790, LIN 180.00
4. Location Town of Edinburg
5. Description Replace the structure

6. Purpose and Justification The structure is deficient. Condition Rating 3.667

7. Status of Plans: (check)

<input type="checkbox"/> Plans not needed	<input type="checkbox"/> Surveys completed	<input type="checkbox"/> Sketch plans completed
<input type="checkbox"/> Nothing done on plans	<input type="checkbox"/> Work on Plans scheduled	<input type="checkbox"/> Detail plans in preparation
<input checked="" type="checkbox"/> Preliminary estimate received	<input type="checkbox"/> Sketch plans in preparation	<input type="checkbox"/> Detail plans completed

8. Estimated Cost: (Required County Funding)

2022 - Engineering	\$	-
Site Acquisition	\$	-
Construction	\$	1,485,000
Other (Insp.)	\$	-
TOTAL	\$	1,485,000

11. Proposed Method of Financing:

Obligations	\$	-
Current Revenues	\$	-
Special Assessments	\$	-
User Charges	\$	-
State and Federal Aid	\$	-
Reserves	\$	1,485,000
Other		
TOTAL	\$	1,485,000

9. Proposed Method of Construction:
 Contract Municipal Employees

10. Estimated Project Expenditures by Years:

20 23	\$	1,485,000
20 24	\$	-
20 25	\$	-
20 26	\$	-
20 27	\$	-
20 _____		
20 _____		
Later _____		

12. If Obligations are to be issued, State:
Type _____
Period of Years from _____ to _____

13. Effect the Project will have on Operating and Maintenance Expenditures for first three years of operation; (plus or minus)

20 _____	_____
20 _____	_____
20 _____	_____

Submitted By: Chad M. Cooke, P.E., Commissioner of Public Works Date July 2022

Long Range Capital Planning _____ Date _____

Governing Board Action _____ Date _____

Note: Furnish as much of the information requested as is available at the time of preparation. Attach maps and other supporting data that will aid in evaluating the project.

PROJECT NO.	3
PRIORITY NO.	4

20 23 CAPITAL PLAN
INDIVIDUAL CAPITAL PROJECT REQUEST AND ESTIMATE OF COST

1. Department Public Works 2.Division Highway
 3. Project Title CR 64 (Nelson Avenue) over Trib. of Saratoga Lake, LIN 279.20
 4. Location Town of Malta
 5. Description Replace the structure

6. Purpose and Justification The structure is deficient. Condition Rating 5.42

7. Status of Plans: (check)

- | | | |
|---|--|--|
| <input type="checkbox"/> Plans not needed | <input type="checkbox"/> Surveys completed | <input type="checkbox"/> Sketch plans completed |
| <input type="checkbox"/> Nothing done on plans | <input type="checkbox"/> Work on Plans scheduled | <input type="checkbox"/> Detail plans in preparation |
| <input checked="" type="checkbox"/> Preliminary estimate received | <input type="checkbox"/> Sketch plans in preparation | <input type="checkbox"/> Detail plans completed |

8. Estimated Cost: (Required County Funding)

	Engineering	\$ 70,000
	Site Acquisition	\$ -
2024	Construction	\$ 500,000
	Other (Insp.)	\$ -
	TOTAL	\$ 570,000

11. Proposed Method of Financing:

Obligations	\$ -
Current Revenues	\$ -
Special Assessments	\$ -
User Charges	\$ -
State and Federal Aid	\$ -
Reserves	\$ 570,000
Other	
TOTAL	\$ 570,000

9. Proposed Method of Construction:

- Contract Municipal Employees

10. Estimated Project Expenditures by Years:

20 23	\$ 70,000
20 24	\$ 500,000
20 25	\$ -
20 26	\$ -
20 27	\$ -
20 _____	_____
20 _____	_____
Later _____	_____

12. If Obligations are to be issued, State:

Type _____
 Period of Years from _____ to _____

13. Effect the Project will have on Operating and Maintenance Expenditures for first three years of operation; (plus or minus)

20 _____	_____
20 _____	_____
20 _____	_____

Submitted By: Chad M. Cooke, P.E., Commisioner of Public Works Date July 2022

Long Range Capital Planning _____ Date _____

Governing Board Action _____ Date _____

Note: Furnish as much of the information requested as is available at the time of preparation. Attach maps and other supporting data that will aid in evaluating the project.

PROJECT NO.	4
PRIORITY NO.	3

20 23 CAPITAL PLAN
INDIVIDUAL CAPITAL PROJECT REQUEST AND ESTIMATE OF COST

1. Department Public Works 2.Division Highway
 3. Project Title Replace the CR 47 (Rowland Street) Bridge over Rowland Hollow Creek, LIN 319.60.
 4. Location Town of Milton
 5. Description Replace the structure

6. Purpose and Justification The structure is deficient. Condition Rating 4.10

7. Status of Plans: (check)

<input type="checkbox"/> Plans not needed	<input type="checkbox"/> Surveys completed	<input type="checkbox"/> Sketch plans completed
<input type="checkbox"/> Nothing done on plans	<input type="checkbox"/> Work on Plans scheduled	<input type="checkbox"/> Detail plans in preparation
<input checked="" type="checkbox"/> Preliminary estimate received	<input type="checkbox"/> Sketch plans in preparation	<input type="checkbox"/> Detail plans completed

8. Estimated Cost: (Required County Funding)

2022	Engineering	\$	-
	Site Acquisition	\$	-
	Construction	\$	528,000
	Other (Insp.)	\$	-
	TOTAL	\$	528,000

11. Proposed Method of Financing:

Obligations	\$	-
Current Revenues	\$	-
Special Assessments	\$	-
User Charges	\$	-
State and Federal Aid	\$	-
Reserves	\$	528,000
Other		
TOTAL	\$	528,000

9. Proposed Method of Construction:
 Contract Municipal Employees

10. Estimated Project Expenditures by Years:

20 23	\$	528,000
20 24	\$	-
20 25	\$	-
20 26	\$	-
20 27	\$	-
20 _____		
20 _____		
Later		

12. If Obligations are to be issued, State:
 Type _____
 Period of Years from _____ to _____

13. Effect the Project will have on Operating and Maintenance Expenditures for first three years of operation; (plus or minus)

20 _____	_____
20 _____	_____
20 _____	_____

Submitted By: Chad M. Cooke, P.E., Commisioner of Public Works Date July 2022

Long Range Capital Planning _____ Date _____

Governing Board Action _____ Date _____

Note: Furnish as much of the information requested as is available at the time of preparation. Attach maps and other supporting data that will aid in evaluating the project.

PROJECT NO.	1
PRIORITY NO.	1

20 23 CAPITAL PLAN
INDIVIDUAL CAPITAL PROJECT REQUEST AND ESTIMATE OF COST

1. Department Public Works 2.Division Highway
 3. Project Title Coons Crossing Road over Anthony Kill Replacement, BIN 2202570, LIN 10.00, SA # 317, PIN 1761.78
 4. Location Town of Halfmoon
 5. Description Replace the structure

6. Purpose and Justification The structure is deficient. Condition Rating 5.154

7. Status of Plans: (check)
 Plans not needed Surveys completed Sketch plans completed
 Nothing done on plans Work on Plans scheduled Detail plans in preparation
 Preliminary estimate received Sketch plans in preparation Detail plans completed

8. Estimated Cost: (Required County Funding)

2021-22 Engineering	\$	-
Site Acquisition	\$	-
Construction	\$	1,313,000
Other (Insp.)		Incl.
TOTAL	\$	1,313,000

11. Proposed Method of Financing:

Obligations	\$	-
Current Revenues	\$	-
Special Assessments	\$	-
User Charges	\$	-
State Aid	15%	\$ 196,950
Federal Aid	80%	\$ 1,050,400
Reserves	5%	\$ 65,650
Other		
TOTAL		\$ 1,313,000

9. Proposed Method of Construction:
 Contract Municipal Employees

10. Estimated Project Expenditures by Years:

20 23	\$	1,313,000
20 24	\$	-
20 25	\$	-
20 26	\$	-
20 27	\$	-
20 _____		
20 _____		
Later _____		

12. If Obligations are to be issued, State:
 Type _____
 Period of Years from _____ to _____

13. Effect the Project will have on Operating and Maintenance Expenditures for first three years of operation; (plus or minus)

20 _____	_____
20 _____	_____
20 _____	_____

Submitted By: Chad M. Cooke, P.E., Commissioner of Public Works Date July 2022
 Long Range Capital Planning _____ Date _____
 Governing Board Action _____ Date _____

Note: Furnish as much of the information requested as is available at the time of preparation. Attach maps and other supporting data that will aid in evaluating the project.

PROJECT NO.	2
PRIORITY NO.	1

20 23 CAPITAL PLAN
INDIVIDUAL CAPITAL PROJECT REQUEST AND ESTIMATE OF COST

1. Department Public Works 2.Division Highway
 3. Project Title Lasher Road over Mourning Kill Rehabilitation, BIN 3304700, LIN 104.00, SA# 318, PIN 1761.79
 4. Location Town of Ballston
 5. Description Rehabilitate the structure

6. Purpose and Justification The structure is deficient. Condition Rating 4.596

7. Status of Plans: (check)

- | | | |
|--|--|---|
| <input type="checkbox"/> Plans not needed | <input type="checkbox"/> Surveys completed | <input type="checkbox"/> Sketch plans completed |
| <input type="checkbox"/> Nothing done on plans | <input type="checkbox"/> Work on Plans scheduled | <input checked="" type="checkbox"/> Detail plans in preparation |
| <input type="checkbox"/> Preliminary estimate received | <input type="checkbox"/> Sketch plans in preparation | <input type="checkbox"/> Detail plans completed |

8. Estimated Cost: (Required County Funding)

2021-22	Engineering	\$ -
	Site Acquisition	\$ -
	Construction	\$ 1,079,800
	Other (Insp.)	\$ -
	TOTAL	\$ 1,079,800

11. Proposed Method of Financing:

Obligations	\$ -
Current Revenues	\$ -
Special Assessments	\$ -
User Charges	\$ -
State Aid 15%	\$ 161,970
Federal Aid 80%	\$ 863,840
Reserves 5%	\$ 53,990
Other	
TOTAL	\$ 1,079,800

9. Proposed Method of Construction:

- Contract Municipal Employees

10. Estimated Project Expenditures by Years:

20 23	\$ 1,079,800
20 24	\$ -
20 25	\$ -
20 26	\$ -
20 27	\$ -
20 _____	_____
20 _____	_____
Later _____	_____

12. If Obligations are to be issued, State:

Type _____
 Period of Years from _____ to _____

13. Effect the Project will have on Operating and Maintenance Expenditures for first three years of operation; (plus or minus)

20 _____	_____
20 _____	_____
20 _____	_____

Submitted By: Chad M. Cooke, P.E., Commisioner of Public Works Date July 2022

Long Range Capital Planning _____ Date _____

Governing Board Action _____ Date _____

Note: Furnish as much of the information requested as is available at the time of preparation. Attach maps and other supporting data that will aid in evaluating the project.

HIGHWAY EQUIPMENT PROGRAM 2023

Priority / Item	Description	Cost	Salvage Value Estimate
1	Replace three (3) Large Dump / Plow Trucks (12 yd), Live Edge Plows	\$900,000	\$12,000
2	Replace one (1) Backhoe with broom and clam bucket and thumb	\$221,000	\$20,000
3	Purchase one (1) Vacuum / Jet Truck	\$640,000	\$0
4	Replace four (4) Pickups	\$286,000	\$6,000
5	Replace one (1) F250 w/ Utility body and V-Plow Truck (B&G)	\$67,000	\$3,500
6	Replace one (1) Chip Truck (13 cy Box)	\$247,250	\$20,000
7	Replace two (2) Carry-Alls	\$154,000	\$13,000
8	Replace one (1) Single Axle Dump (5 yd)	\$160,650	\$3,100
9	Purchase one (1) Rack Truck (B&G)	\$72,500	\$0
10	Purchase one (1) Patch Roller 4 ft Double Drum	\$70,000	\$0
11	Purchase one (1) Mini Excavator With RotoTilt	\$172,000	\$0
12	Replace one (1) Tractor Mower w/ arm	\$125,700	\$500
13	Replace two (2) Variable Message Signs	\$36,500	\$400
14	Purchase three (3) Tilt Deck Trailers - Replace one (1) and Purchase two (2)	\$45,300	\$1,000
15	New Replace one (1) Ventrack 4520Z - Tractor w/ blower, broom, salter (B&G)	\$60,000	\$500
16	Purchase one (1) Dump Trailer (B&G)	\$14,000	\$0
17	Replace one (1) Enclosed Trailer	\$15,000	\$500
18	Purchase one (1) Asphalt Reclaimer / Hot Box Patcher	\$49,000	\$0
19	Replace one (1) Tractor Mower (Airport)	\$178,200	\$500
20	Replace one (1) large 14 ton asphalt roller	\$176,400	\$16,000
21	Purchase one (1) Salt Conveyor	\$149,800	\$0
22	Replace one (1) Turf Mower	\$18,900	\$500
23	Replace one (1) Loader	\$441,000	\$30,000
24	Replace one (1) Wood Chipper	\$110,000	\$17,000
25	Replace one (1) Ford Transit Work Van (B&G)	\$58,000	\$1,500
26	Purchase one (1) Passenger Mini Van (B&G)	\$38,000	\$0
27	Replace one (1) Stump Grinder	\$60,500	\$5,000
28	Replace one (1) Water Truck	\$222,000	\$6,000
Totals		\$4,788,700	\$157,000

HIGHWAY EQUIPMENT PROGRAM 2023

5 YEAR HIGHWAY TRUCK REPLACEMENT BUDGET

EQUIPMENT	#	2023	#	2024	#	2025	#	2026	#	2027
Large Truck (12 yd)	3	\$900,000	2	\$618,000	2	\$636,500	2	\$655,500	2	\$675,000
Medium Truck (5 yd)	1	\$160,650			1	\$170,000			1	\$180,000
Small Truck (3 yd)			1	\$140,000			1	\$149,000		
Carry All	2	\$154,000	2	\$158,620	2	\$163,379	2	\$168,280	2	\$173,328
Pick-Up	4	\$286,000	2	\$134,000	2	\$138,000	2	\$142,500	2	\$146,600
Mehcanics Trucks					1	\$53,000				
Tractor (5th Wheel)			1	\$155,000						
Tree Chip Truck	1	\$247,250							1	\$271,975
Water Truck	1	\$222,000					\$244,200			
Aerial Lift Truck					1	\$158,000				
Utility Body Plow Truck	1	\$67,000								
Transport Vans	1	\$58,000								
Passenger Mini Van	1	\$38,000								
Rack Truck	1	\$72,500								
TOTAL		\$2,205,400		\$1,205,620		\$1,318,879		\$1,359,480		\$1,446,903

5 YEAR HIGHWAY SPECIAL EQUIPMENT REPLACEMENT BUDGET

EQUIPMENT	#	2023	#	2024	#	2025	#	2026	#	2027
Loader	1	\$441,000			1	\$344,000				
Vac / Jet Truck	1	\$640,000								
Backhoe	1	\$221,000	1	\$243,100					1	\$265,200
Roller	1	\$70,000					1	\$136,000	1	\$85,000
Grader										
Dozer					1	\$123,900				
Dump Trailer	1	\$14,000								
Gradall / Excavator	1	\$172,000					1	\$547,100		
Trailer					1	\$157,000				
Tilt Deck Trailer	3	\$45,300				\$16,500			1	\$27,000
Tractor Mower	1	\$125,700	1	\$138,270			1	\$152,097		
Turf Mower	1	\$18,900							1	\$24,000
Wood Chipper	1	\$110,000								
Stump Grinder	1	\$60,500								
Paver						\$106,000				
Skid Steer										
Asphalt Reclaimer	1	\$49,000								
Variable Message Signs	2	\$36,500			2	\$38,690				
Enclosed Trailer	1	\$15,000					1	\$18,000		
Asphalt Roller	1	\$176,400								
Air Compressor			1	\$26,000						
Tractor Mower (Airport)	1	\$178,200								
Construction Roller			1	\$165,000						\$181,500
Salt Conveyor	1	\$149,800								
Ventrack Tractor (B&G)	1	\$60,000								
TOTAL		\$2,583,300		\$572,370		\$786,090		\$853,197		\$582,700
GRAND TOTAL		\$4,788,700		\$1,777,990		\$2,104,969		\$2,212,677		\$2,029,603

HIGHWAY EQUIPMENT PROGRAM 2023

PROJECT NO. _____
PRIORITY NO. <u>1</u>

2023 CAPITAL PLAN INDIVIDUAL EQUIPMENT REQUEST AND ESTIMATE OF COST

1. Department	<u>Public Works</u>	2.Division	<u>Highway</u>
3. Project Title	<u>Replace Three (3), 12 cy Large Plow / Dump Trucks</u>		
4. Location	<u>DPW / Central Garage</u>		
5. Description	<u>Tandem Dump Truck, Diesel Powered, 6 Cylinder. The trucks are used primarily for transporting loose material (such as sand, gravel, or dirt) for construction. These trucks are outfitted for snow removal with plow and wing. A salt spreader is added for the winter months for snow maintenance.</u>		
6. Purpose and Justification	<u>The Tandem Trucks are model year 2007, 2010 and 2014 with 192,200, 189,300, and 177,400 miles respectively. Mechanically, all vehicles are cost prohibitive to repair and showing signs of frame and body fatigue. Several years ago the County began plowing two additional snow routes with its own equipment. The County also now plows the Malta Tech. Park. No new vehicles were added to the fleet for these routes. The County also paves CR 96 and 97 in Waterford which were at one time subcontracted out. This requires the County maintain older vehicles. Currently there are 6 older trucks in the fleet with individual expenses exceeding 40 to 100 percent of the purchase price of the vehicle.</u>		

7. Status of Specifications: (check)

Not Completed Completed

8. Available Under:

State Contract	<input checked="" type="checkbox"/>
County Contract	<input type="checkbox"/>
Competitive Bidding	<input type="checkbox"/>
Municipality	<input type="checkbox"/>
Other (Specify) _____	<input type="checkbox"/>

9. Estimated date needed: 2023

10. Estimated Cost: \$ 900,000

11. Proposed Method of Financing:

Obligations	_____
Current Revenues	_____
Special Assessments	_____
User Charges	_____
State and Federal Aid	_____
Reserves	\$ 900,000
Other	_____
TOTAL	\$ 900,000

12. If Obligations are to be issued, State:

Type _____

Period of Years from _____

13. Effect the Project will have on Operating and Maintenance Expenditures for first three years of operation; (plus or minus)

20 <u>23</u>		\$ 2,400
20 <u>24</u>		\$ 2,400
20 <u>25</u>		\$ 2,400

Submitted By: Chad M. Cooke, P.E., Commissioner of Public Works **Date** July 2022

Long Range Capital Planning _____ **Date** _____

Governing Board Action _____ **Date** _____

Note: **Furnish as much of the information requested as is available at the time of preparation. Attach maps and other supporting data that will aid in evaluating the project.**
9058, 9014, 9030

HIGHWAY EQUIPMENT PROGRAM 2023

PROJECT NO. _____
PRIORITY NO. <u>2</u>

2023 CAPITAL PLAN INDIVIDUAL EQUIPMENT REQUEST AND ESTIMATE OF COST

1. Department Public Works 2. Division Highway
 3. Project Title Replace One (1) Loader / Backhoe
 4. Location Central Garage
 5. Description One (1) Backhoe used for road construction, ditch work sweeping of debris and various tasks on the job site.

6. Purpose and Justification Backhoe is a model year 2006, the many years of use have caused failure of the bushings, drive train and various other components. It is at the end of its life expectancy.

7. Status of Specifications: (check)
 Not Completed Completed

8. Available Under:

State Contract	<input checked="" type="checkbox"/>
County Contract	<input type="checkbox"/>
Competitive Bidding	<input type="checkbox"/>
Municipality	<input type="checkbox"/>
Other (Specify) _____	<input type="checkbox"/>

9. Estimated date needed: 2023

10. Estimated Cost: \$ 221,000

11. Proposed Method of Financing:

Obligations	_____
Current Revenues	_____
Special Assessments	_____
User Charges	_____
State and Federal Aid	_____
Reserves	\$ 221,000
Other	_____
TOTAL	\$ 221,000

12. If Obligations are to be issued, State:
 Type _____
 Period of Years from _____

13. Effect the Project will have on Operating and Maintenance Expenditures for first three years of operation; (plus or minus)

20 <u>23</u>	\$ 400
20 <u>24</u>	\$ 400
20 <u>25</u>	\$ 400

Submitted By: Chad M. Cooke, P.E., Commissioner of Public Works Date July 2022
 Long Range Capital Planning _____ Date _____
 Governing Board Action _____ Date _____

Note: Furnish as much of the information requested as is available at the time of preparation. Attach maps and other supporting data that will aid in evaluating the project.
 9127

HIGHWAY EQUIPMENT PROGRAM 2023

PROJECT NO. _____
PRIORITY NO. <u>3</u>

2023 CAPITAL PLAN INDIVIDUAL EQUIPMENT REQUEST AND ESTIMATE OF COST

1. Department Public Works 2.Division Highway
 3. Project Title Purchase One (1) Vacuum / Jet Truck
 4. Location Central Garage
 5. Description The Vacuum / Jet Truck will be used to clean and flush drainage structures
Also will be used for safe excavations near utilities where hand digging is necessary.

6. Purpose and Justification The vehicle / equipment will help in safe excavations, cleaning of structures, and help to get ahead on the preventative maintenance across the County. Will prevent delays caused by rentals and the borrowing of equipment from other departments that is not always available.
This piece of equipment will also be a backup for the Sewer District.

7. Status of Specifications: (check)
 Not Completed Completed

8. Available Under:

State Contract	<input type="checkbox"/>
County Contract	<input type="checkbox"/>
Competitive Bidding	<input checked="" type="checkbox"/>
Municipality	<input type="checkbox"/>
Other (Specify) _____	<input type="checkbox"/>

9. Estimated date needed: 2023

10. Estimated Cost: \$ 640,000

11. Proposed Method of Financing:

Obligations	
Current Revenues	
Special Assessments	
User Charges	
State and Federal Aid	
Reserves	\$ 640,000
Other	
TOTAL	\$ 640,000

12. If Obligations are to be Issued, State:
 Type _____
 Period of Years _____ from _____

13. Effect the Project will have on Operating and Maintenance Expenditures for first three years of operation; (plus or minus)

20 23	\$	800
20 24	\$	800
20 25	\$	800

Submitted By: Chad M. Cooke, P.E., Commissioner of Public Works Date July 2022
 Long Range Capital Planning _____ Date _____
 Governing Board Action _____ Date _____

Note: Furnish as much of the information requested as is available at the time of preparation. Attach maps and other supporting data that will aid in evaluating the project.

HIGHWAY EQUIPMENT PROGRAM 2023

PROJECT NO. _____
 PRIORITY NO. 4

2023 CAPITAL PLAN INDIVIDUAL EQUIPMENT REQUEST AND ESTIMATE OF COST

1. Department Public Works 2. Division Highway / Buildings and Grounds
 3. Project Title Replace four (4) Pick-Up Trucks
 4. Location Central Garage
 5. Description The pick-up trucks are 3/4 to 1 ton gasoline powered and are used to carry personnel and equipment on various assignments. They are also used for snow removal throughout the winter months.

6. Purpose and Justification The vehicles to be replaced are typically from model years greater than 2001 and mileages greater than 100,000. Repairs to these vehicles are no longer cost effective. The County currently has 5 pick-ups greater than 15 years old (1997 to 2006). Mileages 120K to 254K. Repair costs are \$12K to \$46K. Foreman vehicles typically are passed down to replace these older pickups.

7. Status of Specifications: (check)
 Not Completed Completed

8. Available Under:

State Contract

County Contract

Competitive Bidding

Municipality

Other (Specify) _____

9. Estimated date needed: 2023

10. Estimated Cost: \$ 286,000

11. Proposed Method of Financing:

Obligations	_____
Current Revenues	_____
Special Assessments	_____
User Charges	_____
State and Federal Aid	_____
Reserves	\$ 286,000
Other	_____
TOTAL	\$ 286,000

12. If Obligations are to be issued, State:
 Type _____
 Period of Years from _____ to _____

13. Effect the Project will have on Operating and Maintenance Expenditures for first three years of operation; (plus or minus)

20 23	\$ 300
20 24	\$ 300
20 25	\$ 300

Submitted By: Chad M. Cooke, P.E., Commissioner of Public Works Date July 2022

Long Range Capital Planning _____ Date _____

Governing Board Action _____ Date _____

Note: Furnish as much of the information requested as is available at the time of preparation. Attach maps and other supporting data that will aid in evaluating the project.
 9046,9056,9043 214 or 211

HIGHWAY EQUIPMENT PROGRAM 2023

PROJECT NO. _____
PRIORITY NO. 5

2023 CAPITAL PLAN INDIVIDUAL EQUIPMENT REQUEST AND ESTIMATE OF COST

1. Department Public Works 2.Division Buildings and Grounds
 3. Project Title Replace One (1) Truck with Utility Body and V-Plow
 4. Location Central Garage
 5. Description The pick-up trucks are 3/4 to 1 ton gasoline powered and are used to carry personnel and equipment on various assignments. They are also used for snow removal throughout the winter months.

6. Purpose and Justification Replace one (1) 2015 Chevy 2500 Pickup as it is at the end of its lifespan. This will help with the efficiency of work on our annual projects.

7. Status of Specifications: (check)
 Not Completed Completed

8. Available Under:

State Contract

County Contract

Competitive Bidding

Municipality

Other (Specify) _____

9. Estimated date needed: 2023

10. Estimated Cost: \$ 67,000

11. Proposed Method of Financing:

Obligations	_____
Current Revenues	_____
Special Assessments	_____
User Charges	_____
State and Federal Aid	_____
Reserves	\$ 67,000
Other	_____
TOTAL	\$ 67,000

12. If Obligations are to be issued, State:
 Type _____
 Period of Years from _____

13. Effect the Project will have on Operating and Maintenance Expenditures for first three years of operation; (plus or minus)

20 23	\$ 600
20 24	\$ 600
20 25	\$ 600

Submitted By: Chad M. Cooke P.E., Commissioner of Public Works Date July 2022

Long Range Capital Planning _____ Date _____

Governing Board Action _____ Date _____

Note: Furnish as much of the information requested as is available at the time of preparation. Attach maps and other supporting data that will aid in evaluating the project.
201

HIGHWAY EQUIPMENT PROGRAM 2023

PROJECT NO. _____
PRIORITY NO. <u>6</u>

2023 CAPITAL PLAN INDIVIDUAL EQUIPMENT REQUEST AND ESTIMATE OF COST

1. Department Public Works 2. Division Highway

3. Project Title Replace One (1) Chip Truck for Tree Removal

4. Location Central Garage

5. Description Single-axle, Diesel Powered, 6 Cylinder. These trucks are used year round to tow the wood chipper
The Chip Truck is outfitted with a containment box to collect chips from the removal of tree limbs overhanging
the highway and as part of the overall removal of trees from the highway right of way.

6. Purpose and Justification The Tandem Truck being replaced is model year 2003 and 178,000 miles
Mechanically the vehicle is cost prohibitive to repair. It has many leaks and showing signs of frame and body fatigue.

7. Status of Specifications: (check)

Not Completed Completed

8. Available Under:

State Contract

County Contract

Competitive Bidding

Municipality

Other (Specify) _____

11. Proposed Method of Financing:

Obligations	_____
Current Revenues	_____
Special Assessments	_____
User Charges	_____
State and Federal Aid	_____
Reserves	\$ 247,250
Other	_____
TOTAL	\$ 247,250

9. Estimated date needed: 2023

10. Estimated Cost: \$ 247,250

12. If Obligations are to be issued, State:

Type _____

Period of Years _____ from _____

13. Effect the Project will have on Operating and Maintenance Expenditures for first three years of operation; (plus or minus)

20 23	\$ 2,400
20 24	\$ 2,400
20 25	\$ 2,400

Submitted By: Chad M. Cooke P.E., Commissioner of Public Works Date July 2022

Long Range Capital Planning _____ Date _____

Governing Board Action _____ Date _____

Note: Furnish as much of the information requested as is available at the time of preparation. Attach maps and other supporting data that will aid in evaluating the project.
9038

HIGHWAY EQUIPMENT PROGRAM 2023

PROJECT NO. _____
PRIORITY NO. <u>7</u>

2023 CAPITAL PLAN INDIVIDUAL EQUIPMENT REQUEST AND ESTIMATE OF COST

1. Department Public Works 2.Division Highway
 3. Project Title Replace Two (2) Carry-Alls
 4. Location Central and North Garage
 5. Description Carry-Alls are typically in the half-ton to one -ton range and are used on a daily basis for the transport of material, tools and employees to and from project sites.

6. Purpose and Justification The vehicles to be replaced are model years 2015 and 2018 with odometer readings of 143,000, and 72,000 respectively. Due to their age and/or mileage, repairs to these vehicles are not cost effective. Expenses to date for 2015 and 2018 are about \$24,000 and \$6,000 (this vehicle is out of service with a broken transmission), respectively and represent about 65% of the initial cost of the vehicle.

7. Status of Specifications: (check)
 Not Completed Completed

8. Available Under:

State Contract

County Contract

Competitive Bidding

Municipality

Other (Specify) _____

9. Estimated date needed: 2023

10. Estimated Cost: \$ 154,000

11. Proposed Method of Financing:

Obligations	
Current Revenues	
Special Assessments	
User Charges	
State and Federal Aid	
Reserves	\$ 154,000
Other	
TOTAL	\$ 154,000

12. If Obligations are to be issued, State:
 Type _____
 Period of Years _____ from _____

13. Effect the Project will have on Operating and Maintenance Expenditures for first three years of operation; (plus or minus)

20 23	\$ 300
20 24	\$ 300
20 25	\$ 300

Submitted By: Chad M. Cooke, P.E., Commissioner of Public Works Date July 2022

Long Range Capital Planning _____ Date _____

Governing Board Action _____ Date _____

Note: Furnish as much of the information requested as is available at the time of preparation. Attach maps and other supporting data that will aid in evaluating the project.
 9052, 9047 9041

HIGHWAY EQUIPMENT PROGRAM 2023

PROJECT NO. _____
PRIORITY NO. <u>8</u>

2023 CAPITAL PLAN INDIVIDUAL EQUIPMENT REQUEST AND ESTIMATE OF COST

1. Department Public Works 2.Division Highway
 3. Project Title Replace One (1) Medium Single-Axle Dump, 5 Yard
 4. Location Central Garage
 5. Description Single-axle, Diesel Powered, 6 Cylinder. These trucks are used year round as a utility truck to haul material and personnel or as a special use vehicle.

6. Purpose and Justification Replace one (1) Single Axle Dump (5 cy) - One model year 1999 truck was taken out of service and has not been replaced. This will help with the efficiency of work on our annual projects.

7. Status of Specifications: (check)
 Not Completed Completed

8. Available Under:

State Contract	<input type="checkbox"/>
County Contract	<input type="checkbox"/>
Competitive Bidding	<input checked="" type="checkbox"/>
Municipality	<input type="checkbox"/>
Other (Specify) _____	<input type="checkbox"/>

9. Estimated date needed: 2023

10. Estimated Cost: \$ 160,650

11. Proposed Method of Financing:

Obligations	
Current Revenues	
Special Assessments	
User Charges	
State and Federal Aid	
Reserves	\$ 160,650
Other	
TOTAL	\$ 160,650

12. If Obligations are to be issued, State:
 Type _____
 Period of Years _____ from _____

13. Effect the Project will have on Operating and Maintenance Expenditures for first three years of operation; (plus or minus)

20 23	\$ 600
20 24	\$ 600
20 25	\$ 600

Submitted By: Chad M. Cooke P.E., Commissioner of Public Works Date July 2022

Long Range Capital Planning _____ Date _____

Governing Board Action _____ Date _____

Note: Furnish as much of the information requested as is available at the time of preparation. Attach maps and other supporting data that will aid in evaluating the project.
 9105

HIGHWAY EQUIPMENT PROGRAM 2023

PROJECT NO. _____
PRIORITY NO. <u>9</u>

2023 CAPITAL PLAN INDIVIDUAL EQUIPMENT REQUEST AND ESTIMATE OF COST

1. Department Public Works 2.Division Buildings and Grounds
 3. Project Title Purchase One (1) F-250 Truck with Rack Body
 4. Location Central Garage
 5. Description The Rack trucks are 3/4 to 1 ton gasoline powered and are used to carry personnel, materials and equipment on various projects.

6. Purpose and Justification Purchase one (1) 3/4 ton Pickup with a rack body for transporting materials.
This will help with the efficiency of work on our annual projects.

7. Status of Specifications: (check)

Not Completed Completed

8. Available Under:

State Contract
 County Contract
 Competitive Bidding
 Municipality
 Other (Specify) _____

9. Estimated date needed: 2023

10. Estimated Cost: \$ 72,500

11. Proposed Method of Financing:

Obligations	_____
Current Revenues	_____
Special Assessments	_____
User Charges	_____
State and Federal Aid	_____
Reserves	\$ 72,500
Other	_____
TOTAL	\$ 72,500

12. If Obligations are to be Issued, State:

Type _____
 Period of Years from _____

13. Effect the Project will have on Operating and Maintenance Expenditures for first three years of operation; (plus or minus)

20 <u>23</u>	\$ 600
20 <u>24</u>	\$ 600
20 <u>25</u>	\$ 600

Submitted By: Chad M. Cooke P.E., Commissioner of Public Works Date July 2022

Long Range Capital Planning _____ Date _____

Governing Board Action _____ Date _____

Note: Furnish as much of the information requested as is available at the time of preparation. Attach maps and other supporting data that will aid in evaluating the project.

HIGHWAY EQUIPMENT PROGRAM 2023

PROJECT NO. _____
PRIORITY NO. <u>10</u>

2023 CAPITAL PLAN INDIVIDUAL EQUIPMENT REQUEST AND ESTIMATE OF COST

1. Department Public Works 2.Division Highway
 3. Project Title Replace One (1) Driveway Asphalt Patch Roller
 4. Location Central Garage
 5. Description The asphalt roller is used for the compaction of asphalt on recently constructed County roads/driveways. It is used for hand asphalt work along the road in tight spaces and in driveways where larger rollers cannot be used.

6. Purpose and Justification The asphalt roller to be replaced is a model year 2004. Due to the age/use of this piece of equipment, unit is breaking down more often. Repair costs are about \$6,800 which is about 30 percent of original purchase price.

7. Status of Specifications: (check)
 Not Completed Completed

8. Available Under:

State Contract	<input type="checkbox"/>
County Contract	<input type="checkbox"/>
Competitive Bidding	<input checked="" type="checkbox"/>
Municipality	<input type="checkbox"/>
Other (Specify) _____	<input type="checkbox"/>

9. Estimated date needed: 2023

10. Estimated Cost: \$70,000

11. Proposed Method of Financing:

Obligations	
Current Revenues	
Special Assessments	
User Charges	
State and Federal Aid	
Reserves	\$ 70,000
Other	
TOTAL	\$ 70,000

12. If Obligations are to be issued, State:
 Type _____
 Period of Years from _____

13. Effect the Project will have on Operating and Maintenance Expenditures for first three years of operation; (plus or minus)

20 23	\$ 100
20 24	\$ 100
20 25	\$ 100

Submitted By: Chad M. Cooke, P.E., Commissioner of Public Works Date July 2022
 Long Range Capital Planning _____ Date _____
 Governing Board Action _____ Date _____

Note: Furnish as much of the information requested as is available at the time of preparation. Attach maps and other supporting data that will aid in evaluating the project.
 9217

HIGHWAY EQUIPMENT PROGRAM 2023

PROJECT NO. _____
PRIORITY NO. <u>11</u>

2023 CAPITAL PLAN INDIVIDUAL EQUIPMENT REQUEST AND ESTIMATE OF COST

1. Department Public Works 2. Division Highway
 3. Project Title Purchase one (1) Mini Excavator.
 4. Location North Garage / Central Garage
 5. Description A hydraulic mini excavator (digger) is designed for excavation and demolition purposes.
Hydraulic excavators consist of a chassis, boom, and bucket, and move via wheels/tracks.

6. Purpose and Justification The excavator being requested is a small Caterpillar unit for the North Garage and Construction.
It will be used for excavation with tight conditions, underground utility lines, for smaller excavations, maintenance, etc.
The excavator is track mounted and the cab and bucket can rotate allowing good maneuverability in tight spaces.

7. Status of Specifications: (check)
 Not Completed Completed

8. Available Under:

State Contract	<input type="checkbox"/>
County Contract	<input type="checkbox"/>
Competitive Bidding	<input checked="" type="checkbox"/>
Municipality	<input type="checkbox"/>
Other (Specify) _____	<input type="checkbox"/>

11. Proposed Method of Financing:

Obligations	_____
Current Revenues	_____
Special Assessments	_____
User Charges	_____
State and Federal Aid	_____
Reserves	\$ 172,000
Other	_____
TOTAL	\$ 172,000

9. Estimated date needed: 2023

10. Estimated Cost: \$ 172,000

12. If Obligations are to be issued, State:
 Type _____
 Period of Years from _____ to _____

13. Effect the Project will have on Operating and Maintenance Expenditures for first three years of operation; (plus or minus)

20 23	\$	600
20 24	\$	600
20 25	\$	600

Submitted By: Chad M. Cooke, P.E., Commissioner of Public Works Date July 2022

Long Range Capital Planning _____ Date _____

Governing Board Action _____ Date _____

Note: Furnish as much of the information requested as is available at the time of preparation. Attach maps and other supporting data that will aid in evaluating the project.

HIGHWAY EQUIPMENT PROGRAM 2023

PROJECT NO. _____
PRIORITY NO. <u>12</u>

2023 CAPITAL PLAN INDIVIDUAL EQUIPMENT REQUEST AND ESTIMATE OF COST

1. Department Public Works 2. Division Highway
 3. Project Title Replace One (1) Tractor Mower
 4. Location North Garage
 5. Description Tractor Mowers are used for County road right-of-way clearing and property maintenance. The machines are equipped with either a rear flail mower, side sickle bar, or a boom arm with cutter. The mowers are used on a regular basis throughout the summer months.

6. Purpose and Justification Tractor 9314 is a 1978 unit with side flair. Unit has with approx. 6400 hours on the machine. Many years of use show excessive wear and the unit is not safe to operate. It is not cost effective to continue with repairs.

7. Status of Specifications: (check)
 Not Completed Completed

8. Available Under:

State Contract	<input checked="" type="checkbox"/>
County Contract	<input type="checkbox"/>
Competitive Bidding	<input type="checkbox"/>
Municipality	<input type="checkbox"/>
Other (Specify) _____	<input type="checkbox"/>

9. Estimated date needed: _____ 2023

10. Estimated Cost: _____ \$ 125,700

11. Proposed Method of Financing:

Obligations	
Current Revenues	
Special Assessments	
User Charges	
State and Federal Aid	
Reserves	\$ 125,700
Other	
TOTAL	\$ 125,700

12. If Obligations are to be issued, State:
 Type _____
 Period of Years from _____

13. Effect the Project will have on Operating and Maintenance Expenditures for first three years of operation; (plus or minus)

20 23	\$	500
20 24	\$	500
20 25	\$	500

Submitted By: Chad M. Cooke, P.E., Commissioner of Public Works Date July 2022

Long Range Capital Planning _____ Date _____

Governing Board Action _____ Date _____

Note: Furnish as much of the information requested as is available at the time of preparation. Attach maps and other supporting data that will aid in evaluating the project.
 9314

HIGHWAY EQUIPMENT PROGRAM 2023

PROJECT NO. _____
PRIORITY NO. <u>13</u>

2023 CAPITAL PLAN INDIVIDUAL EQUIPMENT REQUEST AND ESTIMATE OF COST

1. Department	<u>Public Works</u>	2. Division	<u>Highway</u>
3. Project Title	<u>Two (2) Variable Message Sign Boards</u>		
4. Location	<u>Central Garage</u>		
5. Description	<u>Portable electronic message sign boards are used on roadways to give motorists information about road construction, road hazards, speed reductions, lane closures, etc.</u>		

6. Purpose and Justification County VMS boards manufactured in 2005 and 2007 are coming to the end of their service life. One unit manufactured in 2005 has completely failed and it is cost prohibitive to repair. Two units from 2005 and 2007 require batteries and LED modules. Modules for these are upwards of \$500 per unit and one sign board may contain up to 12 modules. There is an increase demand/use by the DPW Emergency Services and Sheriff departments.

7. Status of Specifications: (check)

Not Completed Completed

8. Available Under:

State Contract	<input type="checkbox"/>
County Contract	<input type="checkbox"/>
Competitive Bidding	<input checked="" type="checkbox"/>
Municipality	<input type="checkbox"/>
Other (Specify) _____	<input type="checkbox"/>

9. Estimated date needed: 2023

10. Estimated Cost: \$36,500

11. Proposed Method of Financing:

Obligations	_____
Current Revenues	_____
Special Assessments	_____
User Charges	_____
State and Federal Aid	_____
Reserves	\$ 36,500
Other	_____
TOTAL	\$ 36,500

12. If Obligations are to be issued, State:

Type _____

Period of Years from _____

13. Effect the Project will have on Operating and Maintenance Expenditures for first three years of operation; (plus or minus)

<u>20 23</u>	\$	<u>100</u>
<u>20 24</u>	\$	<u>100</u>
<u>20 25</u>	\$	<u>100</u>

Submitted By: Chad M. Cooke, P.E., Commissioner of Public Works **Date** July 2022

Long Range Capital Planning _____ **Date** _____

Governing Board Action _____ **Date** _____

Note: Furnish as much of the information requested as is available at the time of preparation. Attach maps and other supporting data that will aid in evaluating the project.
9388, 9389

HIGHWAY EQUIPMENT PROGRAM 2023

PROJECT NO. _____
PRIORITY NO. <u>14</u>

2023 CAPITAL PLAN INDIVIDUAL EQUIPMENT REQUEST AND ESTIMATE OF COST

1. Department Public Works 2.Division Highway / Buildings and Grounds
 3. Project Title Purchase three (3) Tilt Deck Trailers - Replace one (1) and Purchase two (2) New
 4. Location Central Garage
 5. Description The Tilt Deck Trailers are used to haul materials and equipment to jobsites.

6. Purpose and Justification
The trailer to be replaced is a 1998 trailer that is at the end of its service life. The two to be purchased are similar. The Forman or other trucks are able to haul most equipment to the jobsite for efficiency.
The tractor trailer and lowboy is often busy and have to wait to move equipment.

7. Status of Specifications: (check)
 Not Completed Completed

8. Available Under:

State Contract	<input checked="" type="checkbox"/>
County Contract	<input type="checkbox"/>
Competitive Bidding	<input type="checkbox"/>
Municipality	<input type="checkbox"/>
Other (Specify) _____	<input type="checkbox"/>

9. Estimated date needed: 2023

10. Estimated Cost: \$45,300

11. Proposed Method of Financing:

Obligations	
Current Revenues	
Special Assessments	
User Charges	
State and Federal Aid	
Reserves	\$ 45,300
Other	
TOTAL	\$ 45,300

12. If Obligations are to be issued, State:
 Type _____
 Period of Years from _____

13. Effect the Project will have on Operating and Maintenance Expenditures for first three years of operation; (plus or minus)

20 23	\$ 100
20 24	\$ 100
20 25	\$ 100

Submitted By: Chad M. Cooke, P.E., Commissioner of Public Works Date July 2022

Long Range Capital Planning _____ Date _____

Governing Board Action _____ Date _____

Note: Furnish as much of the information requested as is available at the time of preparation. Attach maps and other supporting data that will aid in evaluating the project.
 9174R

HIGHWAY EQUIPMENT PROGRAM 2023

PROJECT NO. _____
 PRIORITY NO. 15

**2023 CAPITAL PLAN
 INDIVIDUAL EQUIPMENT REQUEST AND ESTIMATE OF COST**

1. Department Public Works 2.Division Buildings and Grounds
 3. Project Title Replace One (1) Ventrack 4520Z Tractor
 4. Location Central Garage
 5. Description This tractor is used for snow removal, cleaning side walks, salting sidewalks.

6. Purpose and Justification This will replace a 2002 John Deere tractor that is at the end of its lifespan. The new tractor will be more efficient in snow removal at the building complex and sidewalks. This tractor has a salt spreader which will help reduce manpower and overtime hours.

7. Status of Specifications: (check)

Not Completed Completed

8. Available Under:

State Contract
 County Contract
 Competitive Bidding
 Municipality
 Other (Specify) _____

9. Estimated date needed: 2023

10. Estimated Cost: \$60,000

11. Proposed Method of Financing:

Obligations	_____
Current Revenues	_____
Special Assessments	_____
User Charges	_____
State and Federal Aid	_____
Reserves	\$ 60,000
Other	_____
TOTAL	\$ 60,000

12. If Obligations are to be issued, State:

Type _____
 Period of Years _____ from _____

13. Effect the Project will have on Operating and Maintenance Expenditures for first three years of operation; (plus or minus)

20 23	\$ 100
20 24	\$ 100
20 25	\$ 100

Submitted By: Chad M. Cooke, P.E., Commissioner of Public Works Date July 2022

Long Range Capital Planning _____ Date _____

Governing Board Action _____ Date _____

Note: Furnish as much of the information requested as is available at the time of preparation. Attach maps and other supporting data that will aid in evaluating the project.

HIGHWAY EQUIPMENT PROGRAM 2023

PROJECT NO. _____
 PRIORITY NO. 16

2023 CAPITAL PLAN INDIVIDUAL EQUIPMENT REQUEST AND ESTIMATE OF COST

1. Department Public Works 2.Division Buildings and Grounds
 3. Project Title Purchase One (1) Dump Trailer
 4. Location Central Garage
 5. Description The dump trailers are used to haul building debris from building projects including re-models and new construction.

6. Purpose and Justification Buildings and Grounds has been using 30 yd roll off dumpsters. The 30-yard containers are too large to place close to building, take up valuable parking spaces and often require long halls from the building to the unit. A small dump trailer can be located near windows where waste can be emptied. This reduces traffic and debris tracking in the building.

7. Status of Specifications: (check)
 Not Completed Completed

8. Available Under:

State Contract
 County Contract
 Competitive Bidding
 Municipality
 Other (Specify) _____

11. Proposed Method of Financing:

Obligations	_____
Current Revenues	_____
Special Assessments	_____
User Charges	_____
State and Federal Aid	_____
Reserves	\$ 14,000
Other	_____
TOTAL	\$ 14,000

9. Estimated date needed: 2023

10. Estimated Cost: \$ 14,000

12. If Obligations are to be issued, State:
 Type _____
 Period of Years from _____

13. Effect the Project will have on Operating and Maintenance Expenditures for first three years of operation; (plus or minus)

20 <u>23</u>	\$ 100
20 <u>24</u>	\$ 100
20 <u>25</u>	\$ 100

Submitted By: Chad M. Cooke, P.E., Commissioner of Public Works Date July 2022

Long Range Capital Planning _____ Date _____

Governing Board Action _____ Date _____

Note: Furnish as much of the information requested as is available at the time of preparation. Attach maps and other supporting data that will aid in evaluating the project.

HIGHWAY EQUIPMENT PROGRAM 2023

PROJECT NO. _____
PRIORITY NO. <u>17</u>

2023 CAPITAL PLAN INDIVIDUAL EQUIPMENT REQUEST AND ESTIMATE OF COST

1. Department Public Works 2.Division Highway
 3. Project Title Replace One (1) Enclosed Trailer
 4. Location Central Garage
 5. Description The Enclosed trailers are used to haul materials and small tools and equipment to jobsites and safely secure onsite.

6. Purpose and Justification
The trailer to be replaced is a 2009' 7ft x 16ft enclosed trailer. The trailer is wore out, it has a bent tongue, and is at the end of its service life.

7. Status of Specifications: (check)
 Not Completed Completed

8. Available Under:

State Contract	<input type="checkbox"/>
County Contract	<input type="checkbox"/>
Competitive Bidding	<input checked="" type="checkbox"/>
Municipality	<input type="checkbox"/>
Other (Specify) _____	<input type="checkbox"/>

9. Estimated date needed: 2023

10. Estimated Cost: \$ 15,000

11. Proposed Method of Financing:

Obligations ...	
Current Revenues	
Special Assessments	
User Charges	
State and Federal Aid	
Reserves	\$ 15,000
Other	
TOTAL	\$ 15,000

12. If Obligations are to be issued, State:
 Type _____
 Period of Years from _____

13. Effect the Project will have on Operating and Maintenance Expenditures for first three years of operation; (plus or minus)

20 <u>23</u>	\$ 100
20 <u>24</u>	\$ 100
20 <u>25</u>	\$ 100

Submitted By: Chad M. Cooke, P.E., Commissioner of Public Works Date July 2022
 Long Range Capital Planning _____ Date _____
 Governing Board Action _____ Date _____

Note: Furnish as much of the information requested as is available at the time of preparation. Attach maps and other supporting data that will aid in evaluating the project.
 9170

HIGHWAY EQUIPMENT PROGRAM 2023

PROJECT NO. _____
PRIORITY NO. <u>18</u>

2023 CAPITAL PLAN INDIVIDUAL EQUIPMENT REQUEST AND ESTIMATE OF COST

1. Department Public Works 2.Division Highway
 3. Project Title Purchase One (1) Asphalt Reclaimer / Hot Box Patcher
 4. Location Central Garage
 5. Description Diesel fired towable asphalt reclaimer is a thermostatically controlled heating system used to reclaim bulk stored asphalt. Reclaimed asphalt can be heated and maintained at the proper temperature prior to placement.

6. Purpose and Justification
Excess hot-mix-asphalt from road paving projects can be stored at the main garage and utilized throughout the year to repair roads. Reclaimed asphalt can be reheated and used to permanently repair potholes that develop in the winter. Cold mix asphalt is a temporary repair and must be removed in the spring prior to proper repair with hot mix asphalt. The ability to reclaim and maintain asphalt at the proper temperature can allow crews to repair multiple small projects during the day.

7. Status of Specifications: (check)
 Not Completed Completed

8. Available Under:

State Contract	<input checked="" type="checkbox"/>
County Contract	<input type="checkbox"/>
Competitive Bidding	<input type="checkbox"/>
Municipality	<input type="checkbox"/>
Other (Specify) _____	<input type="checkbox"/>

9. Estimated date needed: 2023

10. Estimated Cost: \$ 49,000

11. Proposed Method of Financing:

Obligations	_____
Current Revenues	_____
Special Assessments	_____
User Charges	_____
State and Federal Aid	_____
Reserves	\$ 49,000
Other	_____
TOTAL	<u>\$ 49,000</u>

12. If Obligations are to be issued, State:
 Type _____
 Period of Years from _____

13. Effect the Project will have on Operating and Maintenance Expenditures for first three years of operation; (plus or minus)

20 23	\$ 100
20 24	\$ 100
20 25	\$ 100

Submitted By: Chad M. Cooke, P.E., Commissioner of Public Works Date July 2022
 Long Range Capital Planning _____ Date _____
 Governing Board Action _____ Date _____

Note: Furnish as much of the information requested as is available at the time of preparation. Attach maps and other supporting data that will aid in evaluating the project.

HIGHWAY EQUIPMENT PROGRAM 2023

PROJECT NO. _____
PRIORITY NO. <u>19</u>

2023 CAPITAL PLAN INDIVIDUAL EQUIPMENT REQUEST AND ESTIMATE OF COST

1. Department Public Works 2.Division Highway
 3. Project Title Replace One (1) Tractor Mower 100HP with 20ft Mower (Flexwing)
 4. Location Central Garage
 5. Description Tractor Mowers are used for County road right-of-way clearing and property maintenance. The machines are equipped with either a rear flail mower, side sickle bar, or a boom arm with cutter. The mowers are used on a regular basis throughout the summer months.

6. Purpose and Justification Tractor 9288 is a 1989 unit with Batwings mower. This open cab unit has with approx. 6400 hours on the machine. Many years of use show excessive wear and the unit is not safe to operate. It is not cost effective to continue with repairs. This unit is undersized for its intended use at the airport. Expenses to date are \$8,307 represent about 86% of the initial cost of the vehicle

7. Status of Specifications: (check)
 Not Completed Completed

8. Available Under:

State Contract	<input checked="" type="checkbox"/>
County Contract	<input type="checkbox"/>
Competitive Bidding	<input type="checkbox"/>
Municipality	<input type="checkbox"/>
Other (Specify) _____	<input type="checkbox"/>

9. Estimated date needed: 2023

10. Estimated Cost: \$ 178,200

11. Proposed Method of Financing:

Obligations	_____
Current Revenues	_____
Special Assessments	_____
User Charges	_____
State and Federal Aid	_____
Reserves	\$ 178,200
Other	_____
TOTAL	\$ 178,200

12. If Obligations are to be issued, State:
 Type _____
 Period of Years from _____

13. Effect the Project will have on Operating and Maintenance Expenditures for first three years of operation; (plus or minus)

20 <u>23</u>	\$ 500
20 <u>24</u>	\$ 500
20 <u>25</u>	\$ 500

Submitted By: Chad M. Cooke, P.E., Commissioner of Public Works Date July 2022
 Long Range Capital Planning _____ Date _____
 Governing Board Action _____ Date _____

Note: Furnish as much of the information requested as is available at the time of preparation. Attach maps and other supporting data that will aid in evaluating the project.
 9288

HIGHWAY EQUIPMENT PROGRAM 2023

PROJECT NO. _____
PRIORITY NO. <u>20</u>

2023 CAPITAL PLAN INDIVIDUAL EQUIPMENT REQUEST AND ESTIMATE OF COST

1. Department	<u>Public Works</u>	2.Division	<u>Highway</u>
3. Project Title	<u>Replace One (1) Large Asphalt Compaction Roller</u>		
4. Location	<u>Central Garage</u>		
5. Description	<u>The asphalt compaction roller is used for the initial and final compaction of asphalt placed during road reconstruction projects.</u>		

6. Purpose and Justification The large asphalt compaction roller to be replaced is a model year 2002 unit. The roller has over 3000 hours. The unit is getting to the end of its service life. Breakdowns of a roller during paving creates costly delays to the paving schedule.

7. Status of Specifications: (check)

Not Completed Completed

8. Available Under:

State Contract	<input type="checkbox"/>
County Contract	<input type="checkbox"/>
Competitive Bidding	<input checked="" type="checkbox"/>
Municipality	<input type="checkbox"/>
Other (Specify) _____	<input type="checkbox"/>

11. Proposed Method of Financing:

Obligations	_____
Current Revenues	_____
Special Assessments	_____
User Charges	_____
State and Federal Aid	_____
Reserves	\$ 176,400
Other	_____
TOTAL	\$ 176,400

9. Estimated date needed: _____ 2023

10. Estimated Cost: _____ \$ 176,400

12. If Obligations are to be issued, State:

Type _____

Period of Years from _____

13. Effect the Project will have on Operating and Maintenance Expenditures for first three years of operation; (plus or minus)

20 23	\$	500
20 24	\$	500
20 25	\$	500

Submitted By:	<u>Chad M. Cooke, P.E.</u>	Date	<u>July 2022</u>
Long Range Capital Planning	_____	Date	_____
Governing Board Action	_____	Date	_____

Note: **Furnish as much of the information requested as is available at the time of preparation. Attach maps and other supporting data that will aid in evaluating the project.**

9214

HIGHWAY EQUIPMENT PROGRAM 2023

PROJECT NO. _____
PRIORITY NO. <u>21</u>

2023 CAPITAL PLAN INDIVIDUAL EQUIPMENT REQUEST AND ESTIMATE OF COST

1. Department Public Works 2.Division Highway
 3. Project Title Purchase One (1) Salt Conveyor - Central Garage
 4. Location Central Garage
 5. Description Conveyor with hopper

6. Purpose and Justification This will optimize the loading of the salt shed. This will also allow the salt stored to be maximized for the capacity of the building and allow for less deliveries.
The conveyor can also be used for efficient stockpiling of stones and rubbles.

7. Status of Specifications: (check)
 Not Completed Completed

8. Available Under:

State Contract	<input type="checkbox"/>
County Contract	<input type="checkbox"/>
Competitive Bidding	<input checked="" type="checkbox"/>
Municipality	<input type="checkbox"/>
Other (Specify) _____	<input type="checkbox"/>

9. Estimated date needed: 2023

10. Estimated Cost: \$ 149,800

11. Proposed Method of Financing:

Obligations	_____
Current Revenues	_____
Special Assessments	_____
User Charges	_____
State and Federal Aid	_____
Reserves	\$ 149,800
Other	_____
TOTAL	\$ 149,800

12. If Obligations are to be issued, State:
 Type _____
 Period of Years from _____

13. Effect the Project will have on Operating and Maintenance Expenditures for first three years of operation; (plus or minus)

20 23	\$ 300
20 24	\$ 300
20 25	\$ 300

Submitted By: Chad M. Cooke, P.E., Commissioner of Public Works Date July 2022
 Long Range Capital Planning _____ Date _____
 Governing Board Action _____ Date _____

Note: Furnish as much of the information requested as is available at the time of preparation. Attach maps and other supporting data that will aid in evaluating the project.

HIGHWAY EQUIPMENT PROGRAM 2023

PROJECT NO. _____
PRIORITY NO. 22

2023 CAPITAL PLAN INDIVIDUAL EQUIPMENT REQUEST AND ESTIMATE OF COST

1. Department Public Works 2. Division Highway
 3. Project Title Replace One (1) Turf-Mower
 4. Location North Garage
 5. Description Turf Mowers are used for County property maintenance. The machines are riding mowers utilizing one or more revolving blades to cut grass to an even height. They are similar to residential movers but are larger and are commercial grade.

6. Purpose and Justification The current mower being replaced is a 1990 mower. This unit is breaking down with increasing frequency. The mower is near the end of its service life.

7. Status of Specifications: (check)
 Not Completed Completed

8. Available Under:

State Contract

County Contract

Competitive Bidding

Municipality

Other (Specify) _____

9. Estimated date needed: 2023

10. Estimated Cost: \$ 18,900

11. Proposed Method of Financing:

Obligations	_____
Current Revenues	_____
Special Assessments	_____
User Charges	_____
State and Federal Aid	_____
Reserves	\$ 18,900
Other	_____
TOTAL	\$ 18,900

12. If Obligations are to be issued, State:
 Type _____
 Period of Years from _____

13. Effect the Project will have on Operating and Maintenance Expenditures for first three years of operation; (plus or minus)

20 23	\$ 100
20 24	\$ 100
20 25	\$ 100

Submitted By: Chad M. Cooke, P.E., Commissioner of Public Works Date July 2022

Long Range Capital Planning _____ Date _____

Governing Board Action _____ Date _____

Note: Furnish as much of the information requested as is available at the time of preparation. Attach maps and other supporting data that will aid in evaluating the project.
5240

HIGHWAY EQUIPMENT PROGRAM 2023

PROJECT NO. _____
PRIORITY NO. <u>23</u>

2023 CAPITAL PLAN INDIVIDUAL EQUIPMENT REQUEST AND ESTIMATE OF COST

1. Department Public Works 2. Division Highway
 3. Project Title Replace One (1) Loader
 4. Location Central Garage / North Garage
 5. Description Loaders are used primarily for road construction and loading of trucks with construction material at the job site. At the main garage they used to load salt and aggregate onto trucks and move equipment around the property. At the airport they are used during the winter to clear snow.
 6. Purpose and Justification One loader (1997) is a candidate for replacement due to age and maintenance expenses. Over 11,800 Hours. Various components are failing. Transmission issues, engine lacks power and frequent breakdowns are reported. Total expenses are over \$45,000 for this unit. These expenses are equivalent to 30 percent of the initial purchase price.

7. Status of Specifications: (check)

Not Completed Completed

8. Available Under:

State Contract
 County Contract
 Competitive Bidding
 Municipality
 Other (Specify)

9. Estimated date needed: 2023

10. Estimated Cost: \$ 441,000

11. Proposed Method of Financing:

Obligations	
Current Revenues	
Special Assessments	
User Charges	
State and Federal Aid	
Reserves	\$ 441,000
Other	
TOTAL	\$ 441,000

12. If Obligations are to be issued, State:

Type _____
 Period of Years from _____ to _____

13. Effect the Project will have on Operating and Maintenance Expenditures for first three years of operation; (plus or minus)

20 23	\$ 1,350
20 24	\$ 1,350
20 25	\$ 1,350

Submitted By: Chad M. Cooke, P.E., Commissioner of Public Works

Date July 2022

Long Range Capital Planning _____

Date _____

Governing Board Action _____

Date _____

Note: Furnish as much of the information requested as is available at the time of preparation. Attach maps and other supporting data that will aid in evaluating the project.

9609

HIGHWAY EQUIPMENT PROGRAM 2023

PROJECT NO. _____
PRIORITY NO. <u>24</u>

2023 CAPITAL PLAN INDIVIDUAL EQUIPMENT REQUEST AND ESTIMATE OF COST

1. Department Public Works 2.Division Highway
 3. Project Title Replace One (1) Wood Chippers
 4. Location Central Garage
 5. Description A wood chipper is a machine used for reducing wood (generally tree limbs) into smaller wood chips. A chipper is portable, powered by a separate motor mounted a trailer frame, and suitable for towing behind a truck.

6. Purpose and Justification The 2009 machines have over 4,300 hours on them, respectively. The drums in both machines are damaged and out of balance and require extensive repairs. The feed mechanisms are worn and are in need of replacement. Overall wear and tear on the machines is high. Repairs are frequent. Repairs to date for the 09 (\$19,000) unit is about 40% of the initial purchase price.

7. Status of Specifications: (check)
 Not Completed Completed

8. Available Under:

State Contract	<input checked="" type="checkbox"/>
County Contract	<input type="checkbox"/>
Competitive Bidding	<input type="checkbox"/>
Municipality	<input type="checkbox"/>
Other (Specify) _____	<input type="checkbox"/>

9. Estimated date needed: _____ 2023

10. Estimated Cost: _____ \$ 110,000

11. Proposed Method of Financing:

Obligations	
Current Revenues	
Special Assessments	
User Charges	
State and Federal Aid	
Reserves	\$ 110,000
Other	
TOTAL	\$ 110,000

12. If Obligations are to be issued, State:
 Type _____
 Period of Years from _____

13. Effect the Project will have on Operating and Maintenance Expenditures for first three years of operation; (plus or minus)

20 23	\$ 600
20 24	\$ 600
20 25	\$ 600

Submitted By: Chad M. Cooke, P.E., Commissioner of Public Works Date July 2022

Long Range Capital Planning _____ Date _____

Governing Board Action _____ Date _____

Note: Furnish as much of the information requested as is available at the time of preparation. Attach maps and other supporting data that will aid in evaluating the project.
 9482

HIGHWAY EQUIPMENT PROGRAM 2023

PROJECT NO. _____
PRIORITY NO. <u>25</u>

2023 CAPITAL PLAN INDIVIDUAL EQUIPMENT REQUEST AND ESTIMATE OF COST

1. Department Public Works 2.Division Buildings and Grounds
 3. Project Title Replace One (1) Ford Transit Work Van
 4. Location Central Garage
 5. Description The work van is gasoline powered and are used to carry personnel, Materials and equipment on various projects. The ability to carry tools, equipment and materials makes the projects more efficient.

6. Purpose and Justification Replace one (1) 2007 Chevy Van this vehicle will not pass its next inspection and will be taken out of service. This vehicle is at the end of its lifespan. This will help with the efficiency of work on our annual projects.

7. Status of Specifications: (check)
 Not Completed Completed

8. Available Under:

State Contract

County Contract

Competitive Bidding

Municipality

Other (Specify) _____

9. Estimated date needed: 2023

10. Estimated Cost: \$ 58,000

11. Proposed Method of Financing:

Obligations	
Current Revenues	
Special Assessments	
User Charges	
State and Federal Aid	
Reserves	\$ 58,000
Other	
TOTAL	\$ 58,000

12. If Obligations are to be issued, State:
 Type _____
 Period of Years from _____

13. Effect the Project will have on Operating and Maintenance Expenditures for first three years of operation; (plus or minus)

20 23	\$ 600
20 24	\$ 600
20 25	\$ 600

Submitted By: Chad M. Cooke P.E., Commissioner of Public Works Date July 2022

Long Range Capital Planning _____ Date _____

Governing Board Action _____ Date _____

Note: Furnish as much of the information requested as is available at the time of preparation. Attach maps and other supporting data that will aid in evaluating the project.
 209

HIGHWAY EQUIPMENT PROGRAM 2023

PROJECT NO. _____
PRIORITY NO. <u>26</u>

2023 CAPITAL PLAN INDIVIDUAL EQUIPMENT REQUEST AND ESTIMATE OF COST

1. Department Public Works 2.Division Buildings and Grounds
 3. Project Title Purchase One (1) Passenger Mini Van
 4. Location Central Garage
 5. Description The passenger mini van is gasoline powered and are used to carry personnel to project sites.

6. Purpose and Justification This vehicle is used to transfer the workers to the projects. The previous carpool vehicles have been sent out and scrapped.

7. Status of Specifications: (check)
 Not Completed Completed

8. Available Under:

State Contract	<input type="checkbox"/>
County Contract	<input type="checkbox"/>
Competitive Bidding	<input checked="" type="checkbox"/>
Municipality	<input type="checkbox"/>
Other (Specify) _____	<input type="checkbox"/>

9. Estimated date needed: 2023

10. Estimated Cost: \$ 38,000

11. Proposed Method of Financing:

Obligations	_____
Current Revenues	_____
Special Assessments	_____
User Charges	_____
State and Federal Aid	_____
Reserves	\$ 38,000
Other	_____
TOTAL	\$ 38,000

12. If Obligations are to be issued, State:
 Type _____
 Period of Years from _____

13. Effect the Project will have on Operating and Maintenance Expenditures for first three years of operation; (plus or minus)

<u>20 23</u>	<u>\$ 600</u>
<u>20 24</u>	<u>\$ 600</u>
<u>20 25</u>	<u>\$ 600</u>

Submitted By: Chad M. Cooke P.E., Commissioner of Public Works Date July 2022

Long Range Capital Planning _____ Date _____

Governing Board Action _____ Date _____

Note: Furnish as much of the information requested as is available at the time of preparation. Attach maps and other supporting data that will aid in evaluating the project.

HIGHWAY EQUIPMENT PROGRAM 2023

PROJECT NO. _____
PRIORITY NO. <u>27</u>

2023 CAPITAL PLAN INDIVIDUAL EQUIPMENT REQUEST AND ESTIMATE OF COST

1. Department Public Works 2.Division Highway
 3. Project Title Replace one (1) Stump Grinder
 4. Location Central Garage
 5. Description A Stump Grinder is an engine-powered machine incorporating a cutter wheel with fixed carbide teeth.
The stump cutter is pushed into and through the stump and roots grinding them into small chips.

6. Purpose and Justification The stump grinder is a 2002 unit that is coming to the end of its service life.
Recent repairs include replacement of gearbox at a cost of \$2,600.

7. Status of Specifications: (check)
 Not Completed Completed

8. Available Under:

State Contract	<input checked="" type="checkbox"/>
County Contract	<input type="checkbox"/>
Competitive Bidding	<input type="checkbox"/>
Municipality	<input type="checkbox"/>
Other (Specify) _____	<input type="checkbox"/>

9. Estimated date needed: 2023

10. Estimated Cost: \$60,500

11. Proposed Method of Financing:

Obligations	_____
Current Revenues	_____
Special Assessments	_____
User Charges	_____
State and Federal Aid	_____
Reserves	\$ 60,500
Other	_____
TOTAL	\$ 60,500

12. If Obligations are to be issued, State:
 Type _____
 Period of Years from _____

13. Effect the Project will have on Operating and Maintenance Expenditures for first three years of operation; (plus or minus)

20 23	\$	300
20 24	\$	300
20 25	\$	300

Submitted By: Chad M. Cooke, P.E., Commissioner of Public Works Date July 2022

Long Range Capital Planning _____ Date _____

Governing Board Action _____ Date _____

Note: Furnish as much of the information requested as is available at the time of preparation.
 Attach maps and other supporting data that will aid in evaluating the project.
 9486

HIGHWAY EQUIPMENT PROGRAM 2023

PROJECT NO. _____
PRIORITY NO. <u>28</u>

2023 CAPITAL PLAN INDIVIDUAL EQUIPMENT REQUEST AND ESTIMATE OF COST

1. Department Public Works 2. Division Highway
 3. Project Title Water Truck
 4. Location Central Garage
 5. Description The water trucks are used for flushing out culvert pipes, dust control during construction, and to moisten soil to facilitate solid compaction.

6. Purpose and Justification The County does not have a reliable water truck. The County currently re-uses old large trucks and retrofits them every couple of years before the truck fails and another vehicle needs to be retrofitted. During the 2021 construction season, the County rented a water truck at a cost of approximately \$4,000 per month.

7. Status of Specifications: (check)
 Not Completed Completed

8. Available Under:
 State Contract
 County Contract
 Competitive Bidding
 Municipality
 Other (Specify) _____

9. Estimated date needed: 2023

10. Estimated Cost: \$ 222,000

11. Proposed Method of Financing:

Obligations	_____
Current Revenues	_____
Special Assessments	_____
User Charges	_____
State and Federal Aid	_____
Reserves	\$ 222,000
Other	_____
TOTAL	\$ 222,000

12. If Obligations are to be issued, State:
 Type _____
 Period of Years from _____

13. Effect the Project will have on Operating and Maintenance Expenditures for first three years of operation; (plus or minus)

<u>20 23</u>	\$ 600
<u>20 24</u>	\$ 600
<u>20 25</u>	\$ 600

Submitted By: Chad M. Cooke, P.E., Commissioner of Public Works Date July 2022

Long Range Capital Planning _____ Date _____

Governing Board Action _____ Date _____

Note: Furnish as much of the information requested as is available at the time of preparation. Attach maps and other supporting data that will aid in evaluating the project.
9017

2023 - 2027 AIRPORT CAPITAL IMPROVEMENT PROGRAM

YEAR	PROJECT	GRANT SOURCE	TOTAL	REVENUE		COUNTY SHARE (5% U.N.O. *)
				FEDERAL (90%)	STATE (5%)	
2023	Rehabilitation Runway 5-23 (Design)	Federal AIP	\$ 225,000	\$ 202,500	\$ 11,250	\$ 11,250
	Rehabilitation Western Itinerant Apron (Design)	Federal AIP	\$ 180,000	\$ 162,000	\$ 9,000	\$ 9,000
	Obstruction Removal Acquire Easements - Phase 1 Properties	Federal AIP	\$ 400,000	\$ 360,000	\$ 20,000	\$ 20,000
	Totals for 2023		\$ 805,000	\$ 724,500	\$ 40,250	\$ 40,250
2024	Rehabilitation Runway 5-23 (Construction)	Federal AIP	\$ 7,000,000	\$ 6,300,000	\$ 350,000	\$ 350,000
	Rehabilitation Runway 14-32 (Design)	Federal AIP	\$ 225,000	\$ 202,500	\$ 11,250	\$ 11,250
	Rehabilitation Western Itinerant Apron (Construction)	Federal AIP	\$ 550,000	\$ 495,000	\$ 27,500	\$ 27,500
	Obstruction Removal Acquire Easements - Phase 2 Properties	Federal AIP	\$ 600,000	\$ 540,000	\$ 30,000	\$ 30,000
	Airfield Markings	** N.Y.S.D.O.T.	\$ 750,000	\$ -	\$ 675,000	\$ 75,000
	Totals for 2024		\$ 9,125,000	\$ 7,537,500	\$ 1,093,750	\$ 493,750
2025	Obstruction Removal - Phase 1 & 2 Properties (Design)	Federal AIP	\$ 125,000	\$ 112,500	\$ 6,250	\$ 6,250
	Rehabilitation Runway 14-32 (Construction)	Federal AIP	\$ 7,000,000	\$ 6,300,000	\$ 350,000	\$ 350,000
	Obstruction Removal Acquire Easements - Phase 3 Properties	Federal AIP	\$ 500,000	\$ 450,000	\$ 25,000	\$ 25,000
	Totals for 2025		\$ 7,625,000	\$ 6,862,500	\$ 381,250	\$ 381,250
2026	Obstruction Removal - Phase 1 & 2 Properties (Construction)	Federal AIP	\$ 250,000	\$ 225,000	\$ 12,500	\$ 12,500
	Rehabilitation Taxiway A (Design)	Federal AIP	\$ 190,000	\$ 171,000	\$ 9,500	\$ 9,500
	Airfield Generator	** N.Y.S.D.O.T.	\$ 300,000	\$ -	\$ 270,000	\$ 30,000
	Totals for 2026		\$ 740,000	\$ 396,000	\$ 292,000	\$ 52,000
2027	Obstruction Removal - Phase 3 Properties (Design)	Federal AIP	\$ 125,000	\$ 112,500	\$ 6,250	\$ 6,250
	Rehabilitation Taxiway A (Construction)	Federal AIP	\$ 1,500,000	\$ 1,350,000	\$ 75,000	\$ 75,000
	Totals for 2027		\$ 1,625,000	\$ 1,462,500	\$ 81,250	\$ 81,250

* U.N.O. = Unless Noted Otherwise

** NYS Funded Project. State Share = 90%, County Share = .10%.

PROJECT NO.	1
PRIORITY NO.	1

20 23 CAPITAL PLAN
INDIVIDUAL CAPITAL PROJECT REQUEST AND ESTIMATE OF COST

1. Department Public Works 2.Division Buildings and Grounds/Airport
 3. Project Title Rehabilitation Runway 5-23 (Design)
 4. Location Saratoga County Airport

5. Description The project includes the design for the rehabilitation of Runway 5-23 including the intersection with Runway 14-32 at the Saratoga County Airport. The project will also include the rehabilitation of the edge light system, and runway signage system. The design is planned to include the tie-ins at all Taxiways. The rehabilitation is anticipated to include a mill and overlay; however, a full pavement analysis with testing will be conducted to determine the proper method(s) for rehabilitation.

6. Purpose and Justification Runway 5-23 was last reconstructed in 2001. The pavement shows signs of deterioration due to the harsh climate. The runway pavement age is approaching 25 years of use. The rehabilitation of Runway 5-23 will address the runway conditions and provide an additional 10-years, minimum, of useful life. The Pavement Condition Index (PCI) for the runway was conducted and determined to be 51. The PCI Index range is 0 -100, 0 being the worst and 100 being the best. PCI's less than 70 are eligible for a rehabilitation. A Categorical Exclusion (CATEX) has been submitted.

7. Status of Plans: (check)
- | | | |
|---|---|--|
| <input type="checkbox"/> Plans not Needed | <input type="checkbox"/> Surveys completed | <input type="checkbox"/> Sketch plans completed |
| <input type="checkbox"/> Nothing done on plans | <input type="checkbox"/> Work on Plans scheduled | <input type="checkbox"/> Detail plans in preparation |
| <input checked="" type="checkbox"/> Preliminary estimate received | <input checked="" type="checkbox"/> Sketch plans in preparation | <input type="checkbox"/> Detail plans completed |

8. Estimated Cost:

Engineering	\$	225,000
Site Acquisition	\$	-
Construction	\$	-
Other (Equipment)	\$	-
TOTAL	\$	225,000

11. Proposed Method of Financing:

Obligations	_____
Current Revenues	_____
Special Assessments	_____
User Charges	_____
State and Federal Aid	\$ 213,750
Reserves	\$ 11,250
Other	_____
TOTAL	\$ 225,000

9. Proposed Method of Construction:
 Contract Municipal Employees

10. Estimated Project Expenditures by Years:

20 23	\$	225,000
20 24	\$	-
20 25	\$	-
20 26	\$	-
20 27	\$	-
20 _____		
20 _____		
Later _____		

12. If Obligations are to be issued, State:
 Type _____
 Period of Years from _____ to _____

13. Effect the Project will have on Operating and Maintenance Expenditures for first three years of operation; (plus or minus)

20 23	\$0
20 24	\$0
20 25	\$0

Submitted By: Chad M. Cooke, Commissioner of Public Works Date July 2022
 Long Range Capital Planning _____ Date _____
 Governing Board Action _____ Date _____

Note: Furnish as much of the information requested as is available at the time of preparation. Attach maps and other supporting data that will aid in evaluating the project.

PROJECT NO.	<u>2</u>
PRIORITY NO.	<u>2</u>

20 23 CAPITAL PLAN
INDIVIDUAL CAPITAL PROJECT REQUEST AND ESTIMATE OF COST

1. Department Public Works 2.Division Buildings and Grounds/Airport
 3. Project Title Rehabilitation Western Itinerant Apron (Design)
 4. Location Saratoga County Airport
 5. Description The project includes the design for the rehabilitation of the western portion of the itinerant apron. The project will include milling of partial depth of the existing asphalt and overlaying with new bituminous asphalt. The project will also consider concrete hardstands for parking heavier aircraft for longer periods on the apron. Minor grading will occur off the edge of the apron pavement for transitioning to the existing grade of the surrounding ground. No lighting will be replaced as part of this project.
 6. Purpose and Justification The apron was last rehabilitated in 2010 and shows signs of stress from the long winters in upstate New York. The apron is in deteriorated condition and is in need of rehabilitation to improve safety and increase longevity of use at 5B2. Minor changes to pavement geometry is proposed to bring the connection to Taxiway A up to current standards. The proposed improvements are anticipated to be funded through the Airport Improvement Program (AIP) on land that was acquired using a combination of funding through AIP and the Airport Development Aid Program (ADAP).

7. Status of Plans: (check)

- | | | |
|---|---|--|
| <input type="checkbox"/> Plans not Needed | <input type="checkbox"/> Surveys completed | <input type="checkbox"/> Sketch plans completed |
| <input type="checkbox"/> Nothing done on plans | <input type="checkbox"/> Work on Plans scheduled | <input type="checkbox"/> Detail plans in preparation |
| <input checked="" type="checkbox"/> Preliminary estimate received | <input checked="" type="checkbox"/> Sketch plans in preparation | <input type="checkbox"/> Detail plans completed |

8. Estimated Cost:

Engineering	\$	180,000
Site Acquisition	\$	-
Construction	\$	-
Other (Equipment)	\$	-
TOTAL	\$	180,000

11. Proposed Method of Financing:

Obligations	_____
Current Revenues	_____
Special Assessments	_____
User Charges	_____
State and Federal Aid	\$ 171,000
Reserves	\$ 9,000
Other	_____
TOTAL	\$ 180,000

9. Proposed Method of Construction:

- Contract Municipal Employees

10. Estimated Project Expenditures by Years:

20 23	\$	180,000
20 24	\$	-
20 25	\$	-
20 26	\$	-
20 27	\$	-
20 _____		
20 _____		
Later _____		

12. If Obligations are to be issued, State:

Type _____
 Period of Years from _____ to _____

13. Effect the Project will have on Operating and Maintenance Expenditures for first three years of operation; (plus or minus)

20 23	\$0
20 24	\$0
20 25	\$0

Submitted By: Chad M. Cooke, Commissioner of Public Works Date July 2022

Long Range Capital Planning _____ Date _____

Governing Board Action _____ Date _____

Note: Furnish as much of the information requested as is available at the time of preparation. Attach maps and other supporting data that will aid in evaluating the project.

PROJECT NO.	3
PRIORITY NO.	3

20 22 CAPITAL PLAN
INDIVIDUAL CAPITAL PROJECT REQUEST AND ESTIMATE OF COST

1. Department Public Works 2.Division Buildings and Grounds/Airport
 3. Project Title Obstruction Removal Acquire Easements - Phase 1 Properties
 4. Location Saratoga County Airport
 5. Description Design and acquisition of avigation easements for various runways at the Saratoga County Airport. Efforts include development of easement language, meetings with landowners, development of appraisals, and negotiations with landowners.

6. Purpose and Justification At the completion of the Airport Master Plan in 2014, an airport-wide obstruction analysis identified numerous obstructions on all four runway ends. As part of the Environmental Assessment, willing landowners have been approached to discuss potential easement acquisition, and it is anticipated that multiple landowners may continue in the avigation easement process as part of the grant.

7. Status of Plans: (check)

- | | | |
|---|--|--|
| <input type="checkbox"/> Plans not Needed | <input type="checkbox"/> Surveys completed | <input type="checkbox"/> Sketch plans completed |
| <input type="checkbox"/> Nothing done on plans | <input type="checkbox"/> Work on Plans scheduled | <input type="checkbox"/> Detail plans in preparation |
| <input checked="" type="checkbox"/> Preliminary estimate received | <input type="checkbox"/> Sketch plans in preparation | <input type="checkbox"/> Detail plans completed |

8. Estimated Cost:

Engineering	\$	160,000
Site Acquisition	\$	240,000
Construction		
Other (Equipment)	\$	-
TOTAL	\$	400,000

11. Proposed Method of Financing:

Obligations	_____
Current Revenues	_____
Special Assessments	_____
User Charges	_____
State and Federal Aid	\$ 380,000
Reserves	\$ 20,000
Other	_____
TOTAL	\$ 400,000

9. Proposed Method of Construction:

- Contract Municipal Employees

10. Estimated Project Expenditures by Years:

20 23	\$	400,000
20 24	\$	-
20 25	\$	-
20 26	\$	-
20 27	\$	-
20 _____		
20 _____		
Later _____		

12. If Obligations are to be issued, State:

Type _____
 Period of Years from _____ to _____

13. Effect the Project will have on Operating and Maintenance Expenditures for first three years of operation; (plus or minus)

20 23	\$0
20 24	\$0
20 25	\$0

Submitted By: Chad M. Cooke, Commissioner of Public Works Date July 2021

Long Range Capital Planning _____ Date _____

Governing Board Action _____ Date _____

Note: Furnish as much of the information requested as is available at the time of preparation. Attach maps and other supporting data that will aid in evaluating the project.

MAJOR BUILDING EQUIPMENT/PROJECT PROGRAM

<u>2023</u>		
Buildings # 2, 3 & 4	Replace Aging Circulator Pumps	\$ 250,000
Building # 4 (Grand Jury)	Install Heat Pump System and Controls	\$ 100,000
Public Works Facility	Replace Fuel Island and Pumps	\$ 450,000
Animal Shelter	HVAC Modifications - Phase 1	\$ 680,000
		\$ 1,480,000
<u>2024</u>		
Services Building	Back Up Generator	\$ 450,000
County Wide	New Interior and Exterior Signage	\$ 125,000
Building # 3	Replace 3 Air Handler Units	\$ 225,000
Animal Shelter	HVAC Modifications - Phase 2	\$ 893,000
		\$ 1,693,000
<u>2025</u>		
Building # 5	Replace Slab on Grade	\$ 500,000
Services Building	Replace 11 Roof Top Units	\$ 350,000
		\$ 850,000
<u>2026</u>		
Building # 5 (Auditorium)	Replace 2 Air Handler Units	\$ 100,000
Public Works Facility	Replace Hopper Shed	\$ 300,000
Public Works Facility	Replace Windows In Admin. and Dispatch	\$ 125,000
		\$ 525,000
<u>2027</u>		
Animal Shelter	Replace Generator	\$ 400,000

PROJECT NO. _____
 PRIORITY NO. _____

2023

INDIVIDUAL CAPITAL PROJECT REQUEST AND ESTIMATE OF COST

1. Department Public Works 2.Division Buildings
 3. Project Title Replace Aging Circulator Pumps
 4. Location Buildings 2, 3 & 4
 5. Description There are a total of 10 HVAC water circulator pumps located in these three buildings that are original and require replacement due to their age.

6. Purpose and Justification Replace the pumps while they are still functioning and on a non-emergency basis.

7. Status of Plans: (check)

- | | | |
|---|--|--|
| <input type="checkbox"/> Plans not Needed | <input type="checkbox"/> Surveys completed | <input type="checkbox"/> Sketch plans completed |
| <input type="checkbox"/> Nothing done on plans | <input type="checkbox"/> Work on Plans scheduled | <input type="checkbox"/> Detail plans in preparation |
| <input checked="" type="checkbox"/> Preliminary estimate received | <input type="checkbox"/> Sketch plans in preparation | <input type="checkbox"/> Detail plans completed |

8. Estimated Cost:

Engineering	_____
Site Acquisition	_____
Construction	\$ 250,000
Other ()	_____
TOTAL	\$ 250,000

11. Proposed Method of Financing:

Obligations	_____
Current Revenues	_____
Special Assessments	_____
User Charges	_____
State and Federal Aid	_____
Reserves	_____
Other	\$ 250,000
TOTAL	\$ 250,000

9. Proposed Method of Construction:

- Contract Municipal Employees

10. Estimated Project Expenditures by Years:

20 23	\$ 250,000
20 24	\$ -
20 25	\$ -
20 26	\$ -
20 27	\$ -
20 _____	_____
20 _____	_____
Later _____	_____

12. If Obligations are to be issued, State:
 Type _____
 Period of Years from _____ to _____

13. Effect the Project will have on Operating and Maintenance Expenditures for first three years of operation; (plus or minus)

20 _____	_____
20 _____	_____
20 _____	_____

Submitted By: Chad M. Cooke, P.E., Commissioner of Public Works Date July 2022

Long Range Capital Planning _____ Date _____

Governing Board Action _____ Date _____

Note: Furnish as much of the information requested as is available at the time of preparation. Attach maps and other supporting data that will aid in evaluating the project.

PROJECT NO.	_____
PRIORITY NO.	_____

2023

INDIVIDUAL CAPITAL PROJECT REQUEST AND ESTIMATE OF COST

1. Department Public Works 2.Division Buildings
 3. Project Title Install Heat Pump System and Controls
 4. Location Building # 4 - Grand Jury
 5. Description Remove the existing air handler unit and replace with four wall mounted "mini-split" ductless A/C units.

6. Purpose and Justification The existing air handler unit is old, inefficient and does not properly control humidity or temperature.

7. Status of Plans: (check)

<input type="checkbox"/> Plans not Needed	<input type="checkbox"/> Surveys completed	<input type="checkbox"/> Sketch plans completed
<input type="checkbox"/> Nothing done on plans	<input type="checkbox"/> Work on Plans scheduled	<input type="checkbox"/> Detail plans in preparation
<input checked="" type="checkbox"/> Preliminary estimate received	<input type="checkbox"/> Sketch plans in preparation	<input type="checkbox"/> Detail plans completed

8. Estimated Cost:

Engineering	_____
Site Acquisition	_____
Construction	\$ 100,000
Other ()	_____
TOTAL	\$ 100,000

11. Proposed Method of Financing:

Obligations	_____
Current Revenues	_____
Special Assessments	_____
User Charges	_____
State and Federal Aid	_____
Reserves	_____
Other	\$ 100,000
TOTAL	\$ 100,000

9. Proposed Method of Construction:
 Contract Municipal Employees

10. Estimated Project Expenditures by Years:

20 23	\$ 100,000
20 24	\$ -
20 25	\$ -
20 26	\$ -
20 27	\$ -
20 _____	_____
20 _____	_____
Later _____	_____

12. If Obligations are to be issued, State:
 Type _____
 Period of Years from _____ to _____

13. Effect the Project will have on Operating and Maintenance Expenditures for first three years of operation; (plus or minus)

20 _____	_____
20 _____	_____
20 _____	_____

Submitted By: Chad M. Cooke, P.E., Commissioner of Public Works Date July 2022

Long Range Capital Planning _____ Date _____

Governing Board Action _____ Date _____

Note: **Furnish as much of the information requested as is available at the time of preparation. Attach maps and other supporting data that will aid in evaluating the project.**

PROJECT NO.	_____
PRIORITY NO.	_____

2023

INDIVIDUAL CAPITAL PROJECT REQUEST AND ESTIMATE OF COST

1. Department Public Works 2.Division Buildings
 3. Project Title Replace the Fuel Island and Pumps
 4. Location Public Works Facility
 5. Description Replace the fuel island, canopy and outdated fuel pumps.

6. Purpose and Justification The existing fuel island, canopy and pumps are deteriorated. The fuel pumps are also obsolete and require an upgrade to more current equipment and software.

7. Status of Plans: (check)

- | | | |
|---|--|--|
| <input type="checkbox"/> Plans not Needed | <input type="checkbox"/> Surveys completed | <input type="checkbox"/> Sketch plans completed |
| <input type="checkbox"/> Nothing done on plans | <input type="checkbox"/> Work on Plans scheduled | <input type="checkbox"/> Detail plans in preparation |
| <input checked="" type="checkbox"/> Preliminary estimate received | <input type="checkbox"/> Sketch plans in preparation | <input type="checkbox"/> Detail plans completed |

8. Estimated Cost:

Engineering	_____
Site Acquisition	_____
Construction	\$ 450,000
Other ()	_____
TOTAL	\$ 450,000

11. Proposed Method of Financing:

Obligations	_____
Current Revenues	_____
Special Assessments	_____
User Charges	_____
State and Federal Aid	_____
Reserves	_____
Other	\$ 450,000
TOTAL	\$ 450,000

9. Proposed Method of Construction:

Contract Municipal Employees

10. Estimated Project Expenditures by Years:

20 23	\$ 450,000
20 24	\$ -
20 25	\$ -
20 26	\$ -
20 27	\$ -
20 _____	_____
20 _____	_____
Later _____	_____

12. If Obligations are to be issued, State:

Type _____
 Period of Years from _____ to _____

13. Effect the Project will have on Operating and Maintenance Expenditures for first three years of operation; (plus or minus)

20 _____	_____
20 _____	_____
20 _____	_____

Submitted By: Chad M. Cooke, P.E., Commissioner of Public Works Date July 2022

Long Range Capital Planning _____ Date _____

Governing Board Action _____ Date _____

Note: Furnish as much of the information requested as is available at the time of preparation. Attach maps and other supporting data that will aid in evaluating the project.

PROJECT NO.	_____
PRIORITY NO.	_____

2023

INDIVIDUAL CAPITAL PROJECT REQUEST AND ESTIMATE OF COST

1. Department Public Works 2.Division Buildings
 3. Project Title HVAC Modifications - Phase 1
 4. Location Animal Shelter
 5. Description Modify the current HVAC system to control excessive humidity, airflow and interior temperature which is causing mold and comfort issues.

6. Purpose and Justification In 2022 an HVAC study was completed to determine the cause and solutions to various issues related to the HVAC system including high humidity levels, airflow and interior temperature control.

7. Status of Plans: (check)

<input type="checkbox"/> Plans not Needed	<input checked="" type="checkbox"/> Surveys completed	<input type="checkbox"/> Sketch plans completed
<input type="checkbox"/> Nothing done on plans	<input type="checkbox"/> Work on Plans scheduled	<input type="checkbox"/> Detail plans in preparation
<input checked="" type="checkbox"/> Preliminary estimate received	<input type="checkbox"/> Sketch plans in preparation	<input type="checkbox"/> Detail plans completed

8. Estimated Cost:

Engineering	\$	<u>36,000</u>
Site Acquisition		
Construction	\$	<u>644,000</u>
Other ()		
TOTAL	\$	<u>680,000</u>

11. Proposed Method of Financing:

Obligations	_____
Current Revenues	_____
Special Assessments	_____
User Charges	_____
State and Federal Aid	_____
Reserves	_____
Other	\$ <u>680,000</u>
TOTAL	\$ <u>680,000</u>

9. Proposed Method of Construction:
 Contract Municipal Employees

10. Estimated Project Expenditures by Years:

Phase 1	20 <u>23</u>	\$ <u>680,000</u>
Phase 2	20 <u>24</u>	\$ <u>893,000</u>
	20 <u>25</u>	\$ <u>-</u>
	20 <u>26</u>	\$ <u>-</u>
	20 <u>27</u>	\$ <u>-</u>
	20 _____	_____
	20 _____	_____
Later	_____	_____

12. If Obligations are to be issued, State:
 Type _____
 Period of Years from _____ to _____

13. Effect the Project will have on Operating and Maintenance Expenditures for first three years of operation; (plus or minus)

20 _____	_____
20 _____	_____
20 _____	_____

Submitted By: Chad M. Cooke, P.E., Commissioner of Public Works Date July 2022
 Long Range Capital Planning _____ Date _____
 Governing Board Action _____ Date _____

Note: Furnish as much of the information requested as is available at the time of preparation. Attach maps and other supporting data that will aid in evaluating the project.

ROOF REPLACEMENT/REPAIR PROGRAM

Building # 5	<u>2023</u> Roof Replacement	\$ 1,045,000
	<u>2024</u> TBD	
Correctional Facility	<u>2025</u> Roof Replacement	\$ 1,350,000
TBD	<u>2026</u> TBD	
TBD	<u>2027</u> TBD	

PROJECT NO.	_____
PRIORITY NO.	_____

2023

INDIVIDUAL CAPITAL PROJECT REQUEST AND ESTIMATE OF COST

1. Department Public Works 2.Division Buildings
 3. Project Title Replace the Roof
 4. Location Building # 5, 50 West High Street
 5. Description The current roof was installed in 1994 and is in need of replacement.

6. Purpose and Justification The current roof was installed in 1994 and is in need of replacement.

7. Status of Plans: (check)

- | | | |
|---|--|--|
| <input type="checkbox"/> Plans not Needed | <input type="checkbox"/> Surveys completed | <input type="checkbox"/> Sketch plans completed |
| <input type="checkbox"/> Nothing done on plans | <input type="checkbox"/> Work on Plans scheduled | <input type="checkbox"/> Detail plans in preparation |
| <input checked="" type="checkbox"/> Preliminary estimate received | <input type="checkbox"/> Sketch plans in preparation | <input type="checkbox"/> Detail plans completed |

8. Estimated Cost:

Engineering	\$	95,000
Site Acquisition		
Construction	\$	950,000
Other ()		
TOTAL	\$	1,045,000

11. Proposed Method of Financing:

Obligations	_____
Current Revenues	_____
Special Assessments	_____
User Charges	_____
State and Federal Aid	_____
Reserves	_____
Other	\$ 1,045,000
TOTAL	\$ 1,045,000

9. Proposed Method of Construction:

- Contract Municipal Employees

10. Estimated Project Expenditures by Years:

20 23	\$	1,045,000
20 24	\$	-
20 25	\$	-
20 26	\$	-
20 27	\$	-
20 _____		
20 _____		
Later _____		

12. If Obligations are to be issued, State:

Type _____
 Period of Years from _____ to _____

13. Effect the Project will have on Operating and Maintenance Expenditures for first three years of operation; (plus or minus)

20 _____	_____
20 _____	_____
20 _____	_____

Submitted By: Chad M. Cooke, P.E., Commissioner of Public Works Date July 2022

Long Range Capital Planning _____ Date _____

Governing Board Action _____ Date _____

Note: Furnish as much of the information requested as is available at the time of preparation. Attach maps and other supporting data that will aid in evaluating the project.

PARKING LOT RECONSTRUCTION PROGRAM

	<u>2023</u>		
County Farm Road Access Road CR45 to Fuel Island	Repair/Repave	\$	75,000
	<u>2024</u>		
Correctional Facility Parking Lot	Repair/Repave	\$	138,000
	<u>2025</u>		
Public Works Front and Rear Parking Lots	Repair/Repave	\$	292,000
	<u>2026</u>		
County Farm Road Access Road Fuel Island to the Pump House, Building W2	Repair/Repave	\$	105,000
	<u>2027</u>		
	TBD		

PROJECT NO.	_____
PRIORITY NO.	_____

2023

INDIVIDUAL CAPITAL PROJECT REQUEST AND ESTIMATE OF COST

1. Department Public Works 2.Division Buildings
 3. Project Title Reconstruct the County Farm Complex Access Road from CR 45 to the Fuel Island
 4. Location County Farm Road Complex
 5. Description Reconstruct the County Farm Complex Access Road from CR 45 to the Fuel Island

6. Purpose and Justification The access road is deteriorated and in need of reconstruction

7. Status of Plans: (check)

<input type="checkbox"/> Plans not Needed	<input type="checkbox"/> Surveys completed	<input type="checkbox"/> Sketch plans completed
<input type="checkbox"/> Nothing done on plans	<input type="checkbox"/> Work on Plans scheduled	<input type="checkbox"/> Detail plans in preparation
<input checked="" type="checkbox"/> Preliminary estimate received	<input type="checkbox"/> Sketch plans in preparation	<input type="checkbox"/> Detail plans completed

8. Estimated Cost:

Engineering	_____
Site Acquisition	_____
Construction	\$ 75,000
Other ()	_____
TOTAL	\$ 75,000

11. Proposed Method of Financing:

Obligations	_____
Current Revenues	_____
Special Assessments	_____
User Charges	_____
State and Federal Aid	_____
Reserves	_____
Other	\$ 75,000
TOTAL	\$ 75,000

9. Proposed Method of Construction:
 Contract Municipal Employees

10. Estimated Project Expenditures by Years:

20 23	\$ 75,000
20 24	\$ -
20 25	\$ -
20 26	\$ -
20 27	\$ -
20 _____	_____
20 _____	_____
Later _____	_____

12. If Obligations are to be issued, State:
 Type _____
 Period of Years from _____ to _____

13. Effect the Project will have on Operating and Maintenance Expenditures for first three years of operation; (plus or minus)

20 _____	_____
20 _____	_____
20 _____	_____

Submitted By: Chad M. Cooke, P.E., Commissioner of Public Works Date July 2022

Long Range Capital Planning _____ Date _____

Governing Board Action _____ Date _____

Note: Furnish as much of the information requested as is available at the time of preparation. Attach maps and other supporting data that will aid in evaluating the project.



SARATOGA COUNTY CAPITAL PLAN
PROJECT REQUEST FORM

Received:
Approved:
Project No.:
Priority No.:

In accordance with the Saratoga County Capital Budget Procedure, Department Heads may bring forth any Capital item and request review for inclusion in the County's Capital program. In general, any item costing more than \$25,000 and having a useful life of more than five years shall be reviewed. More information on criteria for inclusion in the Capital Plan is available on the County Intranet.

Department Heads shall submit this form to the County Administrator and outline the project goals and justification.

Department: **Animal Shelter**

Division: **Dept. 35**

Estimated Total Cost: **\$ 25,000.00**

Estimated Cost Breakdown by Category
\$25,000 7094 Building Components

Estimated Cost Breakdown by Year
\$25,000 2023

Anticipated Source of Revenue
County Budget

Project Description
Replace metal roof on crematory building (approx. 38' x 25')



SARATOGA COUNTY CAPITAL PLAN
PROJECT REQUEST FORM

Purpose and Justification

Building is approximately 25 years old; roof has been leaking for a long time.

Impact on County staff, space needs, and/or other operational impacts

This facility is critical for animal shelter operations and needs a sound roof. The building houses the cremator (incinerator), freezers, storage of HVAC filters, etc., rabies processing room and specimen packaging supplies.

Project Status

DPW has secured a quote, attached. A budget number of \$25,000 would cover this plus contingencies.

Status of Plans or Studies, if Necessary

If approved, plan to replace this roof in 2023.

Department Head: Penny Heritage Date: 09/22/2022

Long Range Capital Committee Action: _____ Date: _____

Board of Supervisors Action: _____ Date: _____

Note: Furnish as much of the information requested as is available at the time of preparation. Attach supporting data that will aid in evaluating the project.

RE: Animal Shelter Roof Incinerator Building A3

Speziale, Tom <TSpeziale@saratogacountyny.gov>

Tue 8/9/2022 1:23 PM

To: Abreu, Peter <PAbreu@saratogacountyny.gov>; James Taylor <James@midstateltd.com>

Cc: Penelope A. Heritage <PHeritage@saratogacountyny.gov>

Budget \$25,000. Bids have been consistently coming in over budget.

Thomas A. Speziale <><

Deputy Commissioner of Public Works

tspeziale@saratogacountyny.gov



Saratoga County Department of Public Works

3654 Galway Road

Ballston Spa, New York 12020

(P) 518-885-2235

(F) 518-885-8809

Direct 518-885-8959

STATEMENT OF CONFIDENTIALITY:

This electronic message may contain privileged or confidential information. If you are not the intended recipient of this email, please delete it from your system and advise the sender.

From: Abreu, Peter <PAbreu@saratogacountyny.gov>

Sent: Tuesday, August 9, 2022 1:02 PM

To: Speziale, Tom <TSpeziale@saratogacountyny.gov>; James Taylor <James@midstateltd.com>

Subject: RE: Animal Shelter Roof Incinerator Building A3

Tom - please refer to James email below regarding the budget for the animal shelter roof.

James - thank you.

Peter B. Abreu, P.E.

Saratoga County DPW

3654 Galway Road

Ballston Spa, NY 12020

518-885-2235 ext 6103

FW: Animal Shelter Roof Incinerator Building A3

Abreu, Peter <PAbreu@saratogacountyny.gov>

Tue 8/9/2022 1:20 PM

To: Penelope A. Heritage <PHeritage@saratogacountyny.gov>

Penny,

See budget number for incinerator building roof. I would add 10 percent to give you a budget of \$20,000.

Thank you

Peter B. Abreu, P.E.
Saratoga County DPW
3654 Galway Road
Ballston Spa, NY 12020
518-885-2235 ext 6103

From: James Taylor <James@midstateltd.com>
Sent: Tuesday, August 9, 2022 10:13 AM
To: Abreu, Peter <PAbreu@saratogacountyny.gov>
Subject: RE: Animal Shelter Roof Incinerator Building A3

CAUTION: This email originated from outside of the organization. Do not click links or open attachments unless you recognize the sender and know the content is safe.

Peter,

I would budget \$15,000 to 18,000 to mechanically attach 5/8 securrock and fully adhere .060 EPDM with new metal drip edge.

James Taylor

Project Coordinator

1105 Catalyn Street

Schenectady, NY 12303

James@midstateltd.com

T - 518.374.1461

F - 518.381.6820

www.Midstateltd.com

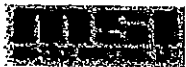

Celebrating Over 50 Years of Service!



This message is confidential. It may also be privileged or otherwise protected by work product immunity or other legal rules. If you have received it by mistake, please let us know by e-mail reply and delete it from your system. If you are not the intended recipient, you may not copy this message or disclose its contents to anyone. Please note that if this e-mail message contains a forwarded message or is a reply to a prior message, some or all of the contents of this message or any attachments may not have been produced by the sender.

From: Abreu, Peter <PAbreu@saratogacountyny.gov>
Sent: Thursday, August 4, 2022 4:01 PM
To: James Taylor <James@midstateltd.com>
Subject: Animal Shelter Roof Incinerator Building A3

James,

We have an incinerator in one of our buildings and the metal roof is about 25 years old and is leaking quite often. We would like to replace the roof next year. Would you be able to give us a budget number for a new metal roof or a membrane roof or some other option you think may be appropriate. No insulation for this building roof. I would need a budget number by Friday 8/12!

The building is metal framed and the roof measures about 38 feet by 25 feet. I attached a couple of photos and a layout.

Please let me know if you help out.

Thank you.

Peter B. Abreu, P.E.
Saratoga County DPW
3654 Galway Road
Ballston Spa, NY 12020
518-885-2235 ext 6103

CONFIDENTIALITY NOTICE -- This email is intended only for the person(s) named in the message header. Unless otherwise indicated, it contains information that is confidential, privileged and/or exempt from disclosure under applicable law. If you have received this message in error, please notify the sender of the error and delete the message. This message (including any attachments) may contain confidential, proprietary, privileged and/or private information. The information is intended to be for the use of the individual or entity designated above. If you are not the intended recipient of this message, please notify the



SARATOGA COUNTY CAPITAL PLAN
PROJECT REQUEST FORM

Received:
Approved:
Project No.:
Priority No.:

In accordance with the Saratoga County Capital Budget Procedure, Department Heads may bring forth any Capital item and request review for inclusion in the County's Capital program. In general, any item costing more than \$25,000 and having a useful life of more than five years shall be reviewed. More information on criteria for inclusion in the Capital Plan is available on the County Intranet.

Department Heads shall submit this form to the County Administrator and outline the project goals and justification.

Department: **Animal Shelter**

Division: **Dept. 35**

Estimated Total Cost: **\$ 30,000.00**

Estimated Cost Breakdown by Category

To be determined- 7094 Building Components / 7095 Capital Equipment

Estimated Cost Breakdown by Year

\$30,000 2023

Anticipated Source of Revenue

County Budget

Project Description

Upgrade kennel pressure washer system

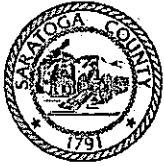

SARATOGA COUNTY CAPITAL PLAN
PROJECT REQUEST FORM

Purpose and Justification

To maintain sanitary standards and prevent spread of disease, dog kennels need to be cleaned and sanitized daily. The existing pressure washer system, which incorporates sanitizing chemicals, has experienced chronic malfunctions and breakdowns. While specialized technicians have been able to troubleshoot, address and temporarily fix some of the issues, a system upgrade is necessary for a longterm solution.

Impact on County staff, space needs, and/or other operational impacts

A proper functioning kennel wash system would ensure consistent sanitation for animal health, prevent waste of costly chemicals, and provide labor saving efficiency.

Project Status

Proposal for system upgrade quoted 8/19/21: \$21,000. Per installer, increases in 2022 for the machines, stainless steel pipe, and components now cost \$40,000. A modified plan, incorporating separate chemical dispensing would range \$25-\$30,000.

Status of Plans or Studies, if Necessary

If approved, plan to proceed with this system upgrade in 2023.

Department Head: Penny Heritage Date: 09/22/2022

Long Range Capital Committee Action: _____ Date: _____

Board of Supervisors Action: _____ Date: _____

Note: Furnish as much of the information requested as is available at the time of preparation. Attach supporting data that will aid in evaluating the project.



P.O. Box 82
 Guilderland Center, N.Y. 12085
 Tax ID# 14-1809668

PROPOSA

Ph: (518) 365-6772
 Fax: (518) 861-7436
 Office: (518) 861-6070

PROPOSAL SUBMITTED TO <i>SARATOGA COUNTY ANIMAL SHELTER</i>	PHONE	DATE <i>8-19-21</i>
STREET	JOB NAME	
CITY	JOB LOCATION	
STATE AND ZIP CODE		

We hereby submit specifications and estimates for the following items:

PROPOSAL TO UPGRADE PRESSURE WASHERS.

THERE WILL BE 3 NEW WASHERS

2 WILL BE IN SAME LOCATION AS OLD MACHINES

1 WILL BE MOUNTED IN QUARANTINE.

NEW 1/2" S.S. STEEL PIPE WILL BE INSTALLED

THERE WILL BE TWO LOCATIONS IN EACH RUN

TO CONNECT HOSE REEL

MACHINE IN QUARRANTINE WILL INCLUDE

ELECTRIC AND WATER

PRESSURE WASHERS WILL BE SMT MANUFACTURE

PROPOSED PRICE FOR EQUIPMENT AND

LABOR TO COMPLETE JOB *\$ 21,000.00*

The Proposer hereby to furnish material and/or labor - complete in accordance with above specifications, for the sum of: *\$ 21,000.00* dollars (\$ *21,000.00*).

Payment to be made as follows:

All material is guaranteed to be as specified. All work to be completed in a workmanlike manner according to standard practices. Any alteration or deviation from above specifications involving extra costs will be executed only upon written orders, and will become an extra charge over and above the estimate.

Authorized Signature: *Arthur Van Buren*

Note: This proposal may be withdrawn by us if not accepted within *120* days.

Acceptance of Proposal - The above prices, specifications and conditions are satisfactory and are hereby accepted. You are authorized to do the work as specified. Payment will be made as outlined above.

Signature: _____

Date of Acceptance: _____

Signature: _____



SARATOGA COUNTY CAPITAL PLAN
PROJECT REQUEST FORM

Received:
Approved:
Project No.:
Priority No.:

In accordance with the Saratoga County Capital Budget Procedure, Department Heads may bring forth any Capital item and request review for inclusion in the County's Capital program. In general, any item costing more than \$25,000 and having a useful life of more than five years shall be reviewed. More information on criteria for inclusion in the Capital Plan is available on the County Intranet.

Department Heads shall submit this form to the County Administrator and outline the project goals and justification.

Department: Sheriff

Division: Corrections Division

Estimated Total Cost: \$ 150,000.00

Estimated Cost Breakdown by Category

Full Body Scanner: \$140,000.00

~~Walk-Through Metal Detector: \$10,000.00~~

Estimated Cost Breakdown by Year

Funding request for 2023 only.

Anticipated Source of Revenue

N/A

Project Description

Purchase of walk-through metal detector and full body scanner (internal and external) used for the detection of contraband.

The Critical Difference: Vertical Scanning

Intercept is a true breakthrough. Other scanners require the person to stand for 7-14 seconds on a moving conveyor belt or platform, transporting them *horizontally* through the x-ray beam. Intercept's patented technology is different; the subject remains stationary, while the scanning apparatus moves *vertically* around them. Why is this better?

- **Best image quality, lowest dose.** Because the beam always passes through the minimum body thickness.
- **Subject safety.** Subjects are often handcuffed, intoxicated, and/or combative. The last place you want them standing is on moving equipment.
- **A quick 3.8 second scan.** Other body scanners require 7-14 seconds, the fastest you can move a person on a conveyor.
- **Ultra-small footprint.** At only 34" deep and 72" wide, Intercept can fit just about anywhere. The footprint of other scanners needs to be about 8' x 8' to move the person.
- **Ultra-small safety zone.** Federal standards require a safety zone around body scanners, where operators and bystanders are prohibited during operation. This is typically a 20' diameter circle around other scanners. Intercept's unique construction allows sophisticated internal radiation shielding, making the safety zone nothing more than the *footprint of the scanner*.
- **Easy Installation and Relocation.** Intercept installs like a refrigerator. It ships fully assembled on wheels, rolls through standard doorways, and plugs into a standard wall socket. A typical installation is 2-hours. Other scanners are too large to install this way; they ship on multiple pallets and build on site.

Case Study: Internal Detection of Drugs

An actual seizure from a US Jail in 2020. A routine scan at booking showed a dark anomaly, consistent with an object concealed in the rectum. When confronted, the subject removed two balloons, one containing cannabis gummies and the other sleeping pills.

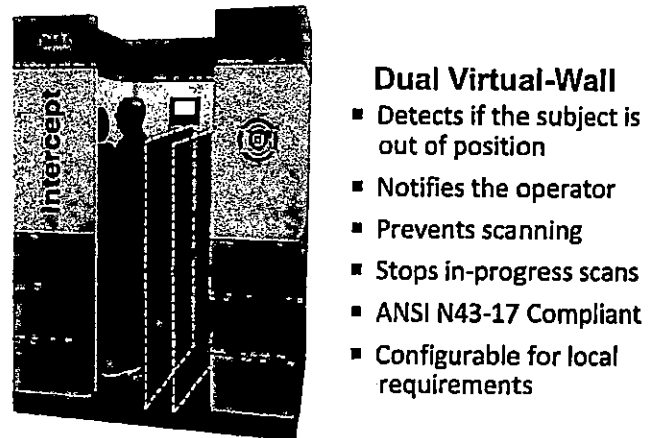
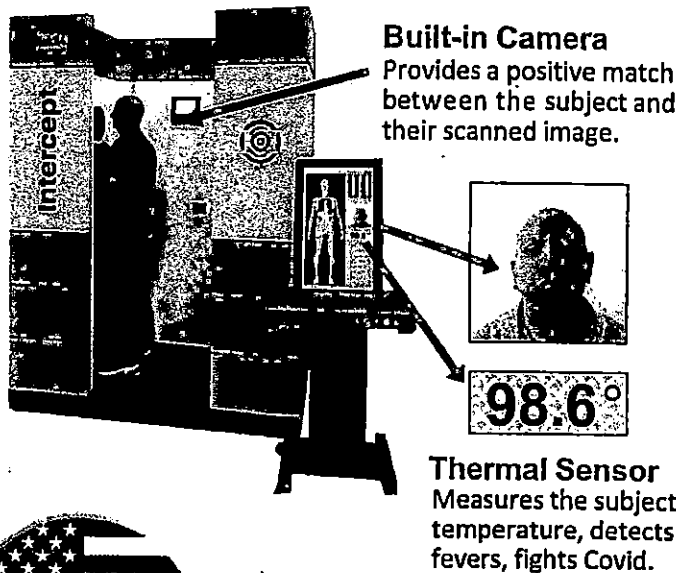
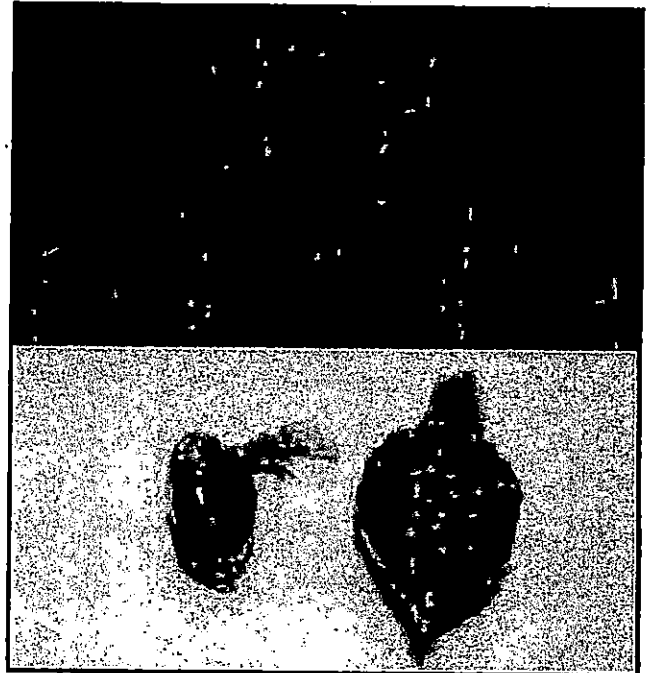

**MADE IN
THE USA**

Tek84 proudly makes Intercept in the USA. Competing products are imported from China, Brazil, Belarus & Western Europe.

Join Hundreds of Jails & Prisons Using CARES and ARP Funds to Buy Body Scanners

Intercept detects concealed threats while reducing Covid transmission- making it an ideal purchase for your unused CARES and American Rescue Plan funds. One staff member can screen up to 180 subjects per hour while maintaining the required 6-foot Covid-safe distance. An FDA approved thermal camera measures the body temperature of each subject to provide an indication of Covid-19 and other infections.

INTERCEPT™

Quick, Convenient, Reliable

Ultra-Small Footprint and Safety Zone

Intercept is extremely compact, requiring a floor space of only 34" x 72". Other body scanners require three times this area. But more important is the **Safety Zone**, where bystanders & operators must be excluded during operation. The Safety Zone for Intercept is nothing more than the scanner footprint. The Safety Zone for other scanners is enormous, 5 to 8 feet away in all directions.

The small footprint, no additional Safety Zone and easy movement allows Intercept to fit just about anywhere. Many facilities even operate Intercept in a hallway, with nothing more than a standard wall plug being needed.

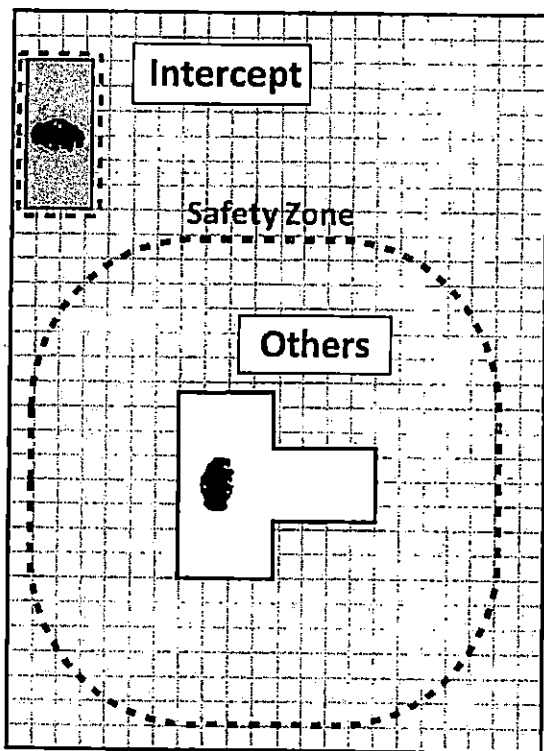

Each square = one foot



Intercept is shipped fully assembled and can be pushed through standard doorways. A typical installation is less than 2-hours. Other body scanners must be shipped on multiple pallets and built at the site over several days.

Intercept™ Specifications

Physical

Footprint: 34" x 72" (86 x 183 cm)
Height: 90" (211 cm) Assembled
79" (201 cm) top removed for transport
Weight: 720 lbs (328 kg)

Electrical

Power: 100/120/230 VAC, 50/60 Hz, 800 watt
Tolerant of poorly regulated power

Environmental

Operating: 32-120°F (0- 50° C)
Humidity: Less than 95%, noncondensing

Radiation Safety

Dose: General-use: 0.25 uSv (25 uRem) per scan, suitable for daily screening;
Limited-use: up to 2.0 uSv (200 uRem) per scan, suitable for weekly screening;
effective dose to subject measured in accordance with ANSI/HPS N43-17-2009
Leakage: Inspection zone is the scanner footprint;
<2 uGy (0.2 mR) in any 1 hour
Standards: Complies with ANSI/HPS N43.17-2009 (Body Scanner Radiation Safety)
Complies with ANSI/IEEE N42.47-2010 (Body Scanner Image Quality)

Intercept is protected under U.S. patents: 10,481,295, 10,705,244, 10,705,245, and 10,845,500. International and other U.S. patents pending.



13495 Gregg Street, Poway, CA 92064
858-676-5382 Sales@Tek84.com

Tek84 develops and manufactures high-technology security products for screening and surveillance. For over three decades we have pioneered the use of ultra-low-dose x-ray imaging. Our products apidly & safely screen for weapons, explosives, drugs, and other contraband. Our engineers created the world's first body scanner (1991); highest resolution surveillance camera (2001); the first drive-through ear bomb-detection-portal (2009); and Intercept, the first inmate scanner with vertical scanning technology (2018).

Multi Zone™ Walk-Through Metal Detector

U.S.A. / International	Description	Color
1171000 / 1171010*	Multi Zone 30" IP 55	Gray
1171001 / 1171011*	Multi Zone 30" IP 65	Gray
1171005 / 1171015*	Multi Zone 32.5** IP 55	Gray
1171006 / 1171016*	Multi Zone 32.5** IP 65	Gray

* Supplied with Euro plug. ** 32" ADA-compliant passageway

★ Enhanced 20-Zone Pinpointing

The Multi Zone's twenty vertical zones provide precise location of one or more objects simultaneously. More than 15 application programs engineered to address the needs of specific use applications, such as schools and special events.

★ Advanced Features and Simple Controls

Menu slider bar allows quick adjustment of setting values. Tamper-free controls via a 5-digit alpha-numeric system that has 60 million code combinations. Auto-Setup function scans electromagnetic environment to select optimal frequency.

Advanced Synchronization

Internal circuitry allows multiple detectors to operate as close as 2 inches from each other.

One Hour Battery Backup

Includes 1-hour emergency back-up battery module in the event of power outage or AC power disconnect. 10-hour operation battery also available.

Directional Counter

Four settings for counting patrons: forward only, reverse only, subtract in reverse, and bidirectional.

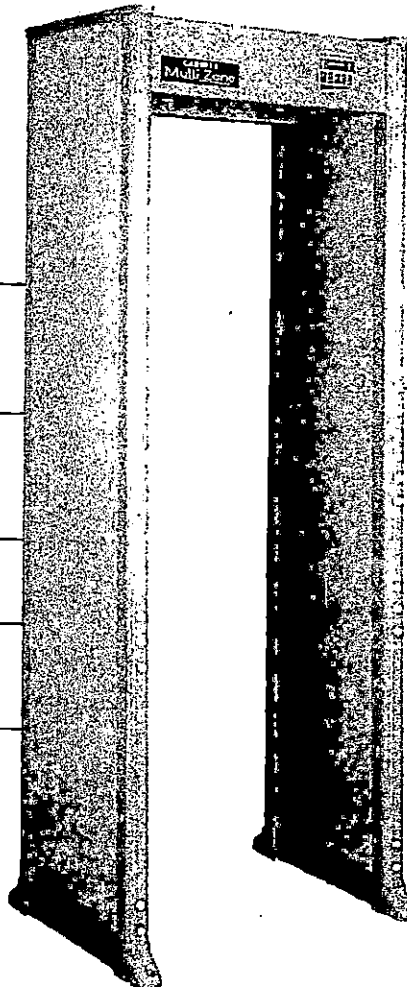

★ Intuitive Menu Design

32-character menu prompts are easy for users to understand (i.e., no codes, acronyms to learn).

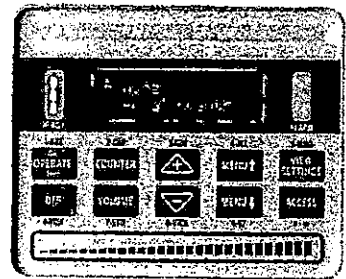

★ Bright LED Indicators

Eye-level green "proceed/ready" symbol, red "wait/alarm" symbol, and zone indicators are highly visible in the brightest sunlight.



Right price, superior performance:
make the Garrett Multi Zone part of
your safe venue plan.



Click for more info

Safety. Security. Peace of Mind.

Garrett's walkthrough metal detectors are highly effective at moving large volumes of patrons through checkpoints with superior detection performance. They are trusted worldwide to safeguard airports, government buildings, correctional facilities, and international sporting contests.

The Garrett PD 6500i walk-through detector—featuring 33 pinpoint zones and advanced discrimination—and the Garrett Multi Zone each offer enhanced features and mobile deployment options. Each includes advanced access control, intuitive operator menus, and full networking ability with other security checkpoint units.

Trust in Garrett, the global leader in detecting technology.



School security package plans available

Simultaneous health and safety screening



Effortless temperature screening. Garrett SmartScan™ technology allows body temperature measurements to be taken during normal security screening with no extra hassle or anxiety. Seamless integration of SmartScan into Garrett walk-through detectors allows your checkpoint to become an efficient, multi-functional, no-contact station.

SMARTSCAN KEY FEATURES:

- Cost effective, fast temperature detection of incoming traffic
- Does not slow down existing screening process
- No technical staff needed to make initial temperature evaluations
- Help reduce costs and the potential for human error
- Battery-operated for ease of use and optimal flexibility
- Intuitive status indicators for startup, calibration, misreads, and elevated temperature alarms
- Visual and audible alarm options
- No dangerous cords or cables or unstable tripod required.
- No additional components that require floor space.
- Quick start operation (single button to power on and begin using)



Click for more info

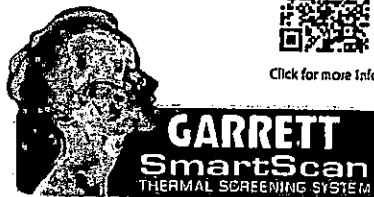

SmartScan Part Numbers:

Product Description	Part No.
SmartScan, Thermal Screening, 30"	1178000
SmartScan, Thermal Screening, 32.5"	1178020

* 32.5" ADA-compliant passageway



SARATOGA COUNTY CAPITAL PLAN
PROJECT REQUEST FORM

Received:
Approved:
Project No.:
Priority No.:

In accordance with the Saratoga County Capital Budget Procedure, Department Heads may bring forth any Capital item and request review for inclusion in the County's Capital program. In general, any item costing more than \$25,000 and having a useful life of more than five years shall be reviewed. More information on criteria for inclusion in the Capital Plan is available on the County Intranet.

Department Heads shall submit this form to the County Administrator and outline the project goals and justification.

Department: **Sheriff** 

Division: Corrections Division

Estimated Total Cost: \$ 1,275,000.00

Estimated Cost Breakdown by Category

- Security Camera Replacement: \$200,000
- Sub-Day Area Installation: \$500,000
- Visitation Area Door Conversion: \$25,000
- Door Lock Replacement: \$100,000
- Door Replacement: \$100,000
- Inmate Dormitory Renovation: \$75,000
- Shower Repair/Replacement: \$275,000

Estimated Cost Breakdown by Year

Funding request for 2023 only.

Anticipated Source of Revenue

None

Project Description

Security Camera Replacement: System was originally installed in 1999. Majority of the cameras are analog and have poor picture quality. New digital cameras will be installed.

Sub-Day Area Installation: Install at least one sub-day area in A-Pod, Unit 1, which will be used to segregate inmates into smaller groups for classification purposes and keep inmates that are assaultive separated from other inmates.

Visitation Area Door Conversion: Current doors cannot be operated by staff in control room. Key only at door location. Doors need to be converted to electric/mechanical locks.

Door Lock Replacement: Door locks are original from when facility opened in 1987. Many of the locks need to be replaced due to constant failure. This will start replacement of locks with additional locks to be replaced in 2024 & 2025.

Door Replacement: Doors are original from opening of facility in 1987. Many doors have rust and rot in locations and need to be replaced. Some do not close properly and have to be adjusted on regular basis. This will start replacement of doors with additional doors to be replaced in 2024 & 2025.

Inmate Dormitory Renovation: Increase size of living space and capacity of area.

Shower Repair/Replacement: Part of ongoing project to repair or replace showers used by inmates. Several showers leak water into adjoining cells, tile missing, shower drains not functioning, poor lighting, poor or no ventilation. Showers are original from when facility opened in 1987. This will start replacement of showers with additional showers to be replaced in 2024.



SARATOGA COUNTY CAPITAL PLAN
PROJECT REQUEST FORM

Purpose and Justification

To modernize areas of the facility, enhance safety & security, increase operational efficiencies, and replace/repair items that are essential to the correctional facility operation.

Impact on County staff, space needs, and/or other operational impacts

Increased safety and security, increase space in inmate living area for additional capacity, and doors, locks, showers that function properly.

Project Status

Subject to review and approval by budget committee and Saratoga County Board of Supervisors.

Status of Plans or Studies, if Necessary

The projects listed in this request have not been subjected to review to date by an engineering/consulting/architectural firm. We do have an estimate for the security camera replacement portion.

Department Head: Michael H. Zurlo Date: 09/20/2022

Long Range Capital Committee Action: _____ Date: _____

Board of Supervisors Action: _____ Date: _____

Note: Furnish as much of the information requested as is available at the time of preparation. Attach supporting data that will aid in evaluating the project.



SARATOGA COUNTY CAPITAL PLAN
PROJECT REQUEST FORM

Received:
Approved:
Project No.:
Priority No.:

In accordance with the Saratoga County Capital Budget Procedure, Department Heads may bring forth any Capital item and request review for inclusion in the County's Capital program. In general, any item costing more than \$25,000 and having a useful life of more than five years shall be reviewed. More information on criteria for inclusion in the Capital Plan is available on the County Intranet.

Department Heads shall submit this form to the County Administrator and outline the project goals and justification.

Department: County Clerk

Division: Records Management

Estimated Total Cost: \$ 112,245.81

Estimated Cost Breakdown by Category

4 Post Shelving and Mobile Storage System: \$79,786.79

Installation: \$20,491.00

Freight: \$11,968.02

Estimated Cost Breakdown by Year

2023: \$112,245.81

Anticipated Source of Revenue

N/A

Project Description

Building 5, Room 112: Provide an additional 1380 cu. ft. of secure storage for DPW, Planning, Veterans, IT, Purchasing, IDA and other departments as necessary. Proposed shelving has a total capacity of 1980 cu. ft. (1 banker box = 1 cu.ft.) Will also alleviate storage issues for the Board of Elections (vault no. 1, room 107) by relocating planning and IDA records to Room 112.

Building 4, Rooms 303, 403 and 404. This portion will net an additional 446 Cu. Ft of inactive storage for the BOS, Dept. of Aging and Youth, Stop DWI, Animal Shelter and Public Health. This will maximize the storage utility of these rooms. Older usable shelving currently in room 404 will be repurposed for rooms 305 & 405, providing an additional 72 Cu. Ft of secure storage.



SARATOGA COUNTY CAPITAL PLAN
PROJECT REQUEST FORM

Purpose and Justification

Records storage areas are not properly equipped with efficient and effective shelving to best utilize the limited space we have. The current shelving is inefficient and inadequate for the security, long-term storage and preservation of inactive records. This shelving will alleviate several of these deficiencies. The secure rolling files will eliminate storage, security and use issues in Board of Elections vault no.1, room 107, building 5. Currently, four departments, use the BOE vault. The additional shelving for building 4 (old jail) will allow us to clean out the lobbies of the jail, provide the Animal Shelter with the proper amount of storage. Also, we currently have departments that are producing more records for inactive storage than inactive records that have met their retention and can be disposed.

Impact on County staff, space needs, and/or other operational impacts

Initial impacts:

- 1) Additional immediate inactive storage for Animal Shelter, BOS, Youth Bureau, Stop DWI, DPW, Planning, IDA, IT, Purchasing.
- 2) Allow BOE to have full use of Vault 1, Room 107. Eliminates the hazardous storage conditions in this vault and creates a more secure environment for BOE use.

Project Status

Quote based upon NYS contract is complete. No further action until approved in 2023 budget.

Status of Plans or Studies, if Necessary

Quote prepared and received August 1, 2022

Department Head: _____ Date: _____

Long Range Capital Committee Action: _____ Date: _____

Board of Supervisors Action: _____ Date: _____

Note: Furnish as much of the information requested as is available at the time of preparation. Attach supporting data that will aid in evaluating the project.

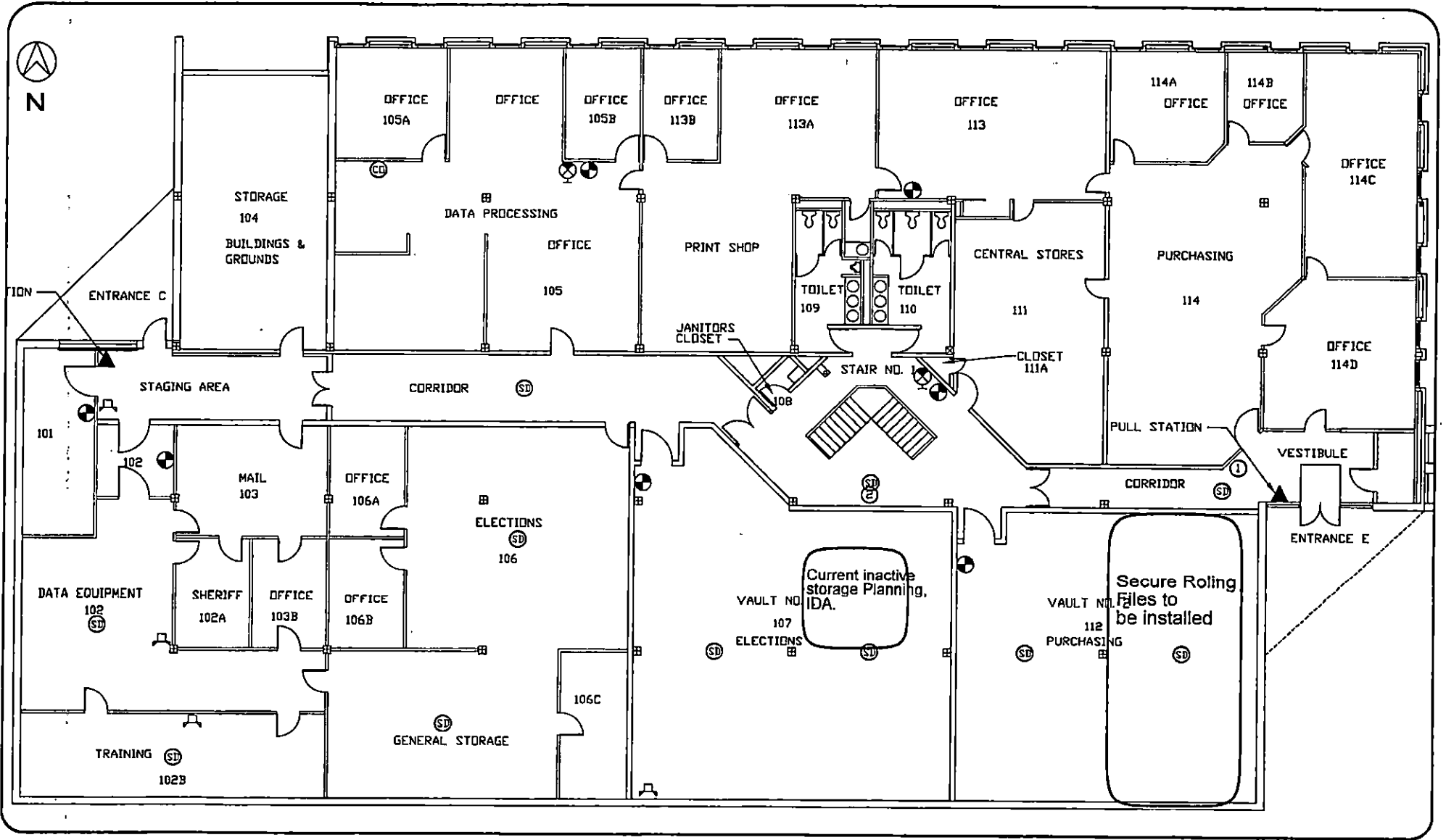

SARATOGA COUNTY DEPARTMENT OF PUBLIC WORKS
 3854 GALWAY ROAD
 BALLSTON SPA, NY 12020

DESIGNED BY: _____ DRAWN BY: M.C. CHECKED BY: _____

KEY:

⊕	EMERGENCY LIGHT	📷	SECURITY CAMERA	⊙	ROCK SWITCH
⊕	FIRE EXTINGUISHER	📄	CARD READER	⊙	BELL
▲	FIRE ALARM BOX	⚡	ELECTRIC LATCH	⊙	KEY CODE LOCK NUMBER
⊕	EXIT SIGN	🔑	CARD KEY MONITOR	L.B.	EMERGENCY LOCKUP BUTTON
⊕	SMOKE DETECTOR	⊕	SYMBOL		
⊕	HEAT DETECTOR	⊕	BELL SYMBOL		

**FIRST FLOOR
 BUILDING NO. 5
 Public Facility
 Saratoga County New York**

SCALE 1/8" = 1'

RECORD OF WORK	
DATE	DESCRIPTION

SCALE 1/8" = 1' Sheet 2 of 3

No

GLENN UNDERWOOD
AUGUST 1, 2022

CORPORATE OVERVIEW

STORAGE SOLUTIONIST

Donnegan Systems was established in 1976 and is a storage solutions provider offering space planning and innovative storage solutions. We handle various industrial, distribution, manufacturing, office, public safety, agriculture, higher education, healthcare, and commercial projects in the New England and Eastern New York markets.

Donnegan Systems is a leader in providing value-added storage solutions to our customers by creating a successful partnership with them throughout the entirety of the project. We pledge to establish lasting relationships with our customers by exceeding their expectations and gaining their trust through exceptional performance by every member of the Donnegan Systems team.

OUR MISSION

Dedication to providing quality products, technical and management services to our customers. We will strive to implement a long-term relationship with our clients based on safety, quality, timely service, and anticipating their needs. To help fulfill this mission, we will treat all employees fairly and involve them in the quality improvement process to insure responsiveness and cost-effective work execution.



TESTIMONIAL

"We are very pleased with the start-to-finish process that Donnegan had provided. The system operates exactly as promised and I am very pleased how everything went.

I want to give high praise to ALL the individuals who were here on site getting the system up and running. They were extremely courteous and showed up on time when they were expected. Communication was flawless with the crew when it came to giving status updates. In today's given workforce pool, Donnegan definitely has some great employees!" - *Production Manager*

"The end result is a system that fulfills all of my requisites and perfectly fits all of our delicate inventory. To say I am thrilled with the end product is an understatement - I am over the moon with how great this experience has been.

Thank you all so much for your help and for providing such superior products and service!" - *Archivist*

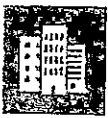

SARATOGA COUNTY

CHARLES FOEHSER II

40 McMASTER STREET
BALLSTON SPA, NY 12020

Thank you very much for this opportunity and your business!

Date: August 1, 2022
Proposal: DONN-SAC72522
Presented by: Glenn Underwood
Office: (800)222-6311 ext. 0
Cell: 508-330-1783
Fax: (508)393-3974
Website: www.donnegan.com

It is understood that the recommendations herein are intended for consideration only by your organization and that the detailed operating advantages are obtainable through the integrated utilization of Donnegan Systems, Inc.'s products and services. Under no circumstances should this information be supplied to anyone not authorized by Donnegan Systems, Inc.

**Donnegan Systems, Inc.
170 Bartlett Street
Northborough, MA 01532**

** This proposal is valid for 14 days.*



SUMMARY

Executivew Overview

Saratoga County is in need of additional storage solutions for their archive records, maps, books and other storage items.

Solution

Charles Foehser II worked closely with Donnegan Systems to design the most space efficient and cost effective storage system for the multiple storage areas. The result is maximized storage space with increased storage capacity.

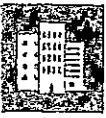

Contents

Summary	i
Contents	ii
1 Equipment Specifications	1
2 Investment Profile	2
3 Customer Acceptance	3
4 Schedule of Values	5
5 Standard Terms and Conditons	6
6 Conditions of Contract	8
7 Appendix	10

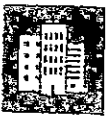

1

EQUIPMENT SPECIFICATIONS

Room 303 & 403

- Spacesaver 4-Post Shelving
- 6 Sections per room
- 6 Levels of shelving
- Per drawing provided

Room 404

- Spacesaver 4-Post Shelving
- 7 Sections of Shelving
- 6 Levels of shelving
- Per drawing provided

Archives Room - Mobile Shelving

- Spacsaver Mobile Shelving System
- 3 Fixed sections of Spacesaver 4-Post Shelving
- 8 Mobile sections of Spacesaver 4-Post Shelving
- 6 Levels of shelving
- Per drawing provided

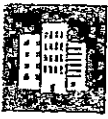

2

INVESTMENT PROFILE

All Rooms for pricing	Total Price
Product 4-Post Shelving and Mobile System \$79,786.79:	
Installation \$20,491.00:	
<ul style="list-style-type: none">• Donnegan Systems, Inc. to deliver and install all shelving per drawing• Installation to take place during normal business hours• Non-Union Rate	
Freight:	
<ul style="list-style-type: none">• Inside delivery charge. 15% of system cost \$11,968.02	
Total Price * State Sales Tax, if applicable, is not included *	\$112,245.81

Group: 20915
Award: 23109

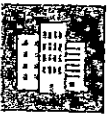

3

CUSTOMER ACCEPTANCE

FINISH SELECTION & ORDER ENTRY PROCESS

Finish Selection:

End Panels: _____(if applicable, see appendix)
Shelving: _____(if applicable, see appendix)
Lockers: _____(if applicable, see appendix)
Type of Floor Covering: _____(if applicable, see appendix)

Order Entry Checklist:

Sign off on drawing: _____
Sign off on proposal description: _____
Submittal of purchase order: _____

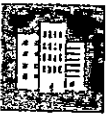

Acceptance

Donnegan Systems, Inc. President Donnegan Systems

Donnegan Systems, Inc. Glenn Underwood

Customer: Saratoga County

Notes:

- 1. Please circle or fill in the above selections at the time of order placement.*
- 2. Pricing is based on standard finish selections. All custom paint finishes (indicated by bold print or in the metallic family) have an up-charge.*
- 3. It is the customer's responsibility to see that the above checklist items have been addressed before the submittal of the purchase order.*

Purchase Orders:

Purchase orders should be made out to the following:

Donnegan Systems, Inc.
170 Bartlett Street
Northborough, MA 01532
Fax# (508)393-5601

Please include finish selections, ship to address, contact name and phone number on your purchase order.

Installation and Support:

All installation work is performed by insured and factory-trained system installers, ensuring high-quality workmanship and accountability. Donnegan Systems, Inc. will coordinate installation with your schedule. All labor is based on straight time labor during normal working hours (7 a.m. to 3:30 p.m.). If overtime is required, additional costs will be incurred.

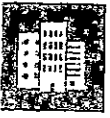

4

SCHEDULE OF VALUES

Schedule of Contract Values

Donnegan Systems, Inc.

Project Name: Saratoga County

Total Project Value: **\$112,245.81** * Does not include State Sales Tax

Item No.	Description of Work	Total
1.	½ Deposit for Material Release - Due at time of order	\$56,122.91
2.	2 nd Payment - Due on shipment of product from manufacturer	\$28,061.45
3.	3 rd Payment - Due upon completion of product installation	\$28,061.45
Grand Total:		\$112,245.81

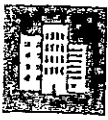

5

STANDARD TERMS AND CONDITIONS

The following are the standard terms and conditions of sale for Donnegan Systems, Inc., and will necessarily be made part of any contract resulting from this proposal.

DELIVERY (Dock, Elevator and Dumpster):

Donnegan Systems, Inc. will notify your designated contact person twenty-four (24) hours prior to delivery. Dock space and/or elevator availability will be arranged by you and made available at no cost to Donnegan Systems, Inc. A dumpster for removal of all shipping and packing materials will be provided at no charge to Donnegan Systems, Inc. the dumpster must be conveniently located and easily accessible at all times during the installation of the equipment.

STORAGE:

If, for any reason, you are not ready to receive the materials and storage is required, storage and handling fees will be added to your invoice.

SPACE REQUIREMENTS:

The space shall be ready for installation and free and clear of all obstructions. If it is not and there is a resulting delay, then the additional person-hours will be billed. The space shall be adequately lit. If additional lighting is required to perform the work safely, the additional cost will be invoiced. It is your responsibility to be certain the space is suitable for the installation of this equipment, i.e., adequate fire protection, clearances, and floor load capacity.

FIRE CODE:

It is the customer's responsibility to verify that the shelving system height is verified on-site prior to placing the purchase order to ensure that proper clearance is maintained.

FREIGHT:

Due to volatility in freight charges, the shipping cost provided on this quote is an ESTIMATE only. Freight costs and the number of truckloads may change. The actual freight cost will be charged at the time of shipment OR on the final invoice. This estimate assumes the product ships in an enclosed van. The freight estimate does NOT include flatbed truck, special equipment, special skidding, or packaging unless the customer specifies at the time of the quote request. Additional charges such as detention fees, re-consignment, refusal/re-delivery, and other unforeseen carrier charges will be added to final freight billing. Shipping and delivery dates are approximate and are not a guarantee of shipment or delivery on any particular date. Time shall not be of the essence of the contract. Seller shall not be liable for delays in or failures of delivery due to strikes or labor troubles, supplier's delays, accidents, fire, flood, acts of God, action by a governmental authority, changes requested by Buyer,



or other causes beyond its reasonable control. Suppose the shipment is delayed at the request of the Buyer. In that case, the Buyer shall make payment as though shipment had been made as specified and for any expenses incurred by Seller due to Buyer's request in delaying shipment; and the material shall be stored at the Buyer's risk and subject to reasonable storage charges.

INSTALLATION:

Installation is in addition to the price of the materials. Labor is planned as straight time unless otherwise noted. Overtime occurring not at Donnegan Systems, Inc.'s discretion will be added to your invoice.

TAXES:

All applicable sales taxes, as required by law, will be billed.

PAYMENT:

This system has been specially designed and will be specially manufactured for your unique requirements. A non-refundable down payment of 50% of the contract amount is due with order, 25% upon shipment from the manufacturer, and the balance 30 days after acceptance. One and one-half (1 1/2) percent interest per month will be charged on any unpaid balance after thirty (30) days. A hold-back of reasonable value is allowed if the installation is not totally complete upon final invoicing without incurring interest charges.

WARRANTY:

The system is warranted against defects in materials in accordance with the given manufacturer's warranty.

INSURANCE CERTIFICATES, PERMITS AND FEES

We reserve the right to pass on any additional costs to obtain insurance certificates, building permits, or miscellaneous fees that have not been previously identified and/or specified in our proposal but are required to complete the project.

CHANGE ORDERS AND OR CANCELLATION:

If, for any reason, you cancel the order, any cancellation, restocking, and handling charges will be invoiced. Change orders requested after receiving your purchase order may also incur additional charges.

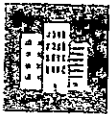

6

CONDITIONS OF CONTRACT

1. It is agreed by the purchaser that this contract, when accepted by the seller, is not subject to cancellation or to any verbal agreement or condition not stipulated in writing on it, and that
2. Title to the goods described on the fact hereof shall not pass until the purchase price is paid in full. The purchaser hereby grants a security interest in said goods to secure payment and performance to the seller. It is mutually agreed that the billing of such goods is for convenience only; and does not carry the title with it, and that
3. In case of default of payment, or in case of removal of said goods or any part thereof without the consent of the seller, or in the event the purchaser shall mortgage or part with the possession of the said property, voluntarily or involuntarily, without the consent of the seller, the latter shall have the right to resume immediate possession of same wherever it may be found, and remove it with or without process of law, and may declare this agreement terminated and may retain all money paid hereunder as liquidated damages and rental for said goods. In the event a claim is placed in an attorney's hands for collection or in the event of litigation, a reasonable attorney's fee and cost shall be added to it, and that
4. In the event that the sale or use of the merchandise herein is subject to any Federal, State, Municipal, or other tax, now or hereafter enacted, the amount of any such tax shall be added to the purchase or rental price.
5. The seller shall not be liable for any delay in shipment or for failure to deliver the goods covered hereunder because of fire, strikes, war, or other emergencies, whether national or state, or due to controls, laws, or regulations issued by any Nation or State, or any political subdivision thereof, or other causes beyond its control. IN NO EVENT SHALL THE SELLER BE LIABLE FOR INDIRECT OR CONSEQUENTIAL DAMAGES SUCH AS BUT NOT LIMITED TO LOSS OF ANTICIPATED PROFITS OR OTHER ECONOMIC LOSS IN CONNECTION WITH OR ARISING OUT OF THE EXISTENCE, FURNISHING, FAILURE TO FURNISH, FUNCTIONING, OR CUSTOMER'S USE OF THE GOODS.
6. All claims for shortage must be made within five (5) days from receipt of goods.
7. Any Equipment sold hereunder is warranted to be in satisfactory operating condition when delivered. Should any part prove defective in material or workmanship during the warranty period, replacement of same will be made without charge. Buyer shall permit full and free access to perform these services when equipment is not portable; otherwise, Buyer shall return equipment for service at



its expense. This warranty does not include replacing parts due to misuse, neglect, damage, burned-out motors, or fuses.

THE FOREGOING WARRANTY AND LIMITATIONS ARE EXCLUSIVE REMEDIES AND ARE IN LIEU OF ALL OTHER WARRANTIES EXPRESS OR IMPLIED, INCLUDING BUT NOT LIMITED TO THE IMPLIED WARRANTIES OF MERCHANTABILITY AND FITNESS FOR A PARTICULAR PURPOSE.

8. To the extent any other written agreement between the parties specifically covering the sale of equipment goods is inconsistent, and such other written agreement shall take precedence over these standard conditions.

9. This contract is subject to our credit department approval. This quotation is made for immediate acceptance and is subject to change without notice. If based on specially printed forms, it presupposes your acceptance of overruns or underruns not exceeding 10% of the quantity ordered.

10. Deliveries are subject to delays from fires, strikes, and other causes beyond our control. We reserve the right to correct clerical errors.

11. This contract shall be construed in accordance with the Laws of the Commonwealth of Massachusetts.

12. Payment terms are 50% with the order, 25% upon shipment from the manufacturer, and the balance 30 days after acceptance.

13. Under any resulting contract, Donnegan Systems, Inc. will retain a security interest and retain all rights as a secured creditor under the Uniform Commercial Code until all checks have been cleared and payment in full has been received. In the event of default, the customer shall pay all collection expenses, including attorney fees

Accepted:

By: _____ Date: _____
Authorized Signature

Title: _____

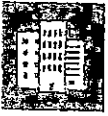

7

APPENDIX

SARATOGA NY, COUNTY OF - RECORDS STORAGE - STATIC

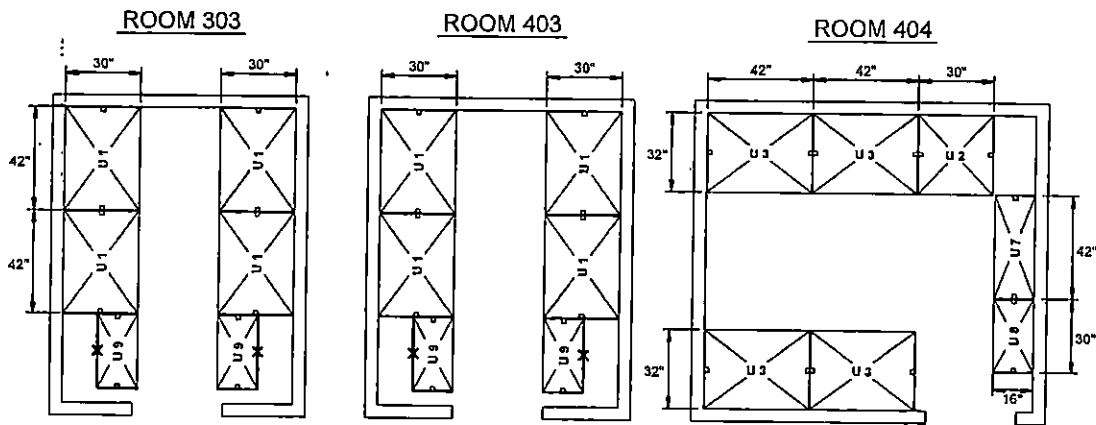

STATIONARY - 4-POST
30" & 42" W x 16", 30" & 32" D

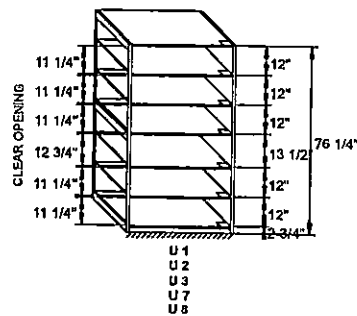

STATIONARY - 4-POST
36" W x 16" D

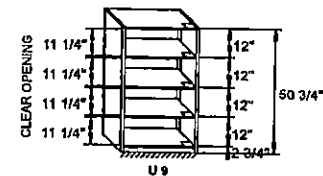

FLOOR PLAN



Project Name: SARATOGA NY, COUNTY OF

Salesperson:
UNDERWOOD, GLENN

Scale
1/4" = 1'

Rev level:

Project #:

Drawn by:
AL

Date Printed:
07/08/2022

APPROVAL
This drawing Approved By:

Dated _____

COPYRIGHT © 2022 SPACESAVER CORPORATION ALL RIGHTS RESERVED

Copyright © 2022 Spacesaver Corporation. This material is proprietary and confidential, and the disclosure, reproduction by photography, film, blueprint or otherwise or incorporation into any information retrieval system without first receiving written approval from Spacesaver Corporation is expressly prohibited by law.

SARATOGA NY, COUNTY OF - RECORDS STORAGE - MOBILE

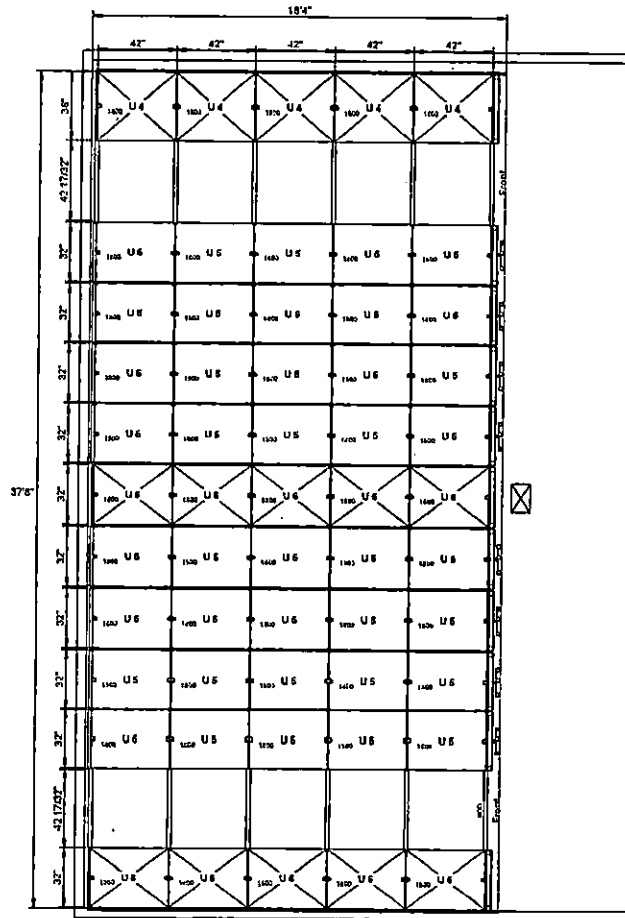

STATIONARY - 4-POST
42" W x 36" D

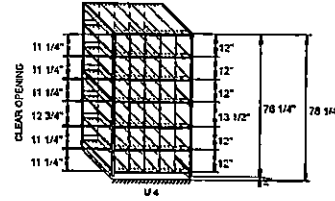

MOBILE - 4-POST
42" W x 32" D

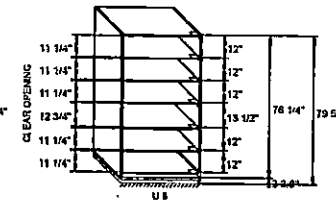

STATIONARY - 4-POST
42" W x 32" D

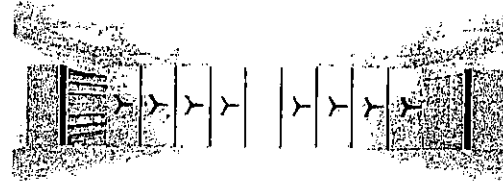
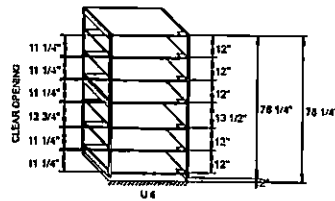

FLOOR PLAN



Project Name: SARATOGA NY, COUNTY OF

Salesperson:
UNDERWOOD, GLENN

Scale
3/16" = 1'

Rev level:

Project #:

Drawn by:

AL

Date Printed:

07/08/2022

APPROVAL
This drawing Approved By:

Dated



SARATOGA COUNTY CAPITAL PLAN
PROJECT REQUEST FORM

Received:
Approved:
Project No.:
Priority No.:

In accordance with the Saratoga County Capital Budget Procedure, Department Heads may bring forth any Capital item and request review for inclusion in the County's Capital program. In general, any item costing more than \$25,000 and having a useful life of more than five years shall be reviewed. More information on criteria for inclusion in the Capital Plan is available on the County Intranet.

Department Heads shall submit this form to the County Administrator and outline the project goals and justification.

Department: Public Health



Division: Environmental Health

Estimated Total Cost: \$ 60,000.00

Estimated Cost Breakdown by Category

2 Chevy Equinox (2023 model year) vehicles at \$30,000 each.

Estimated Cost Breakdown by Year

Both vehicles are proposed to be purchased during the 2023 County Fiscal Year.

Anticipated Source of Revenue

36% of the total cost may be reimbursable under NYSDOH State Aid.

Project Description

n/a



SARATOGA COUNTY CAPITAL PLAN
PROJECT REQUEST FORM

Purpose and Justification

These vehicles will be used by environmental health staff to drive to facilities that are regulated by SCDOH and require inspections.

Impact on County staff, space needs, and/or other operational impacts

None. Travel to conduct on-site inspections of regulated facilities is part of the job descriptions for environmental health staff.

Project Status

N/A

Status of Plans or Studies, if Necessary

N/A

Department Head: Daniel Kuhles Date: 09/23/2022

Long Range Capital Committee Action: _____ Date: _____

Board of Supervisors Action: _____ Date: _____

Note: Furnish as much of the information requested as is available at the time of preparation. Attach supporting data that will aid in evaluating the project.

Build & Price: 2023 Equinox
LS AWD

♥
Saved (0)



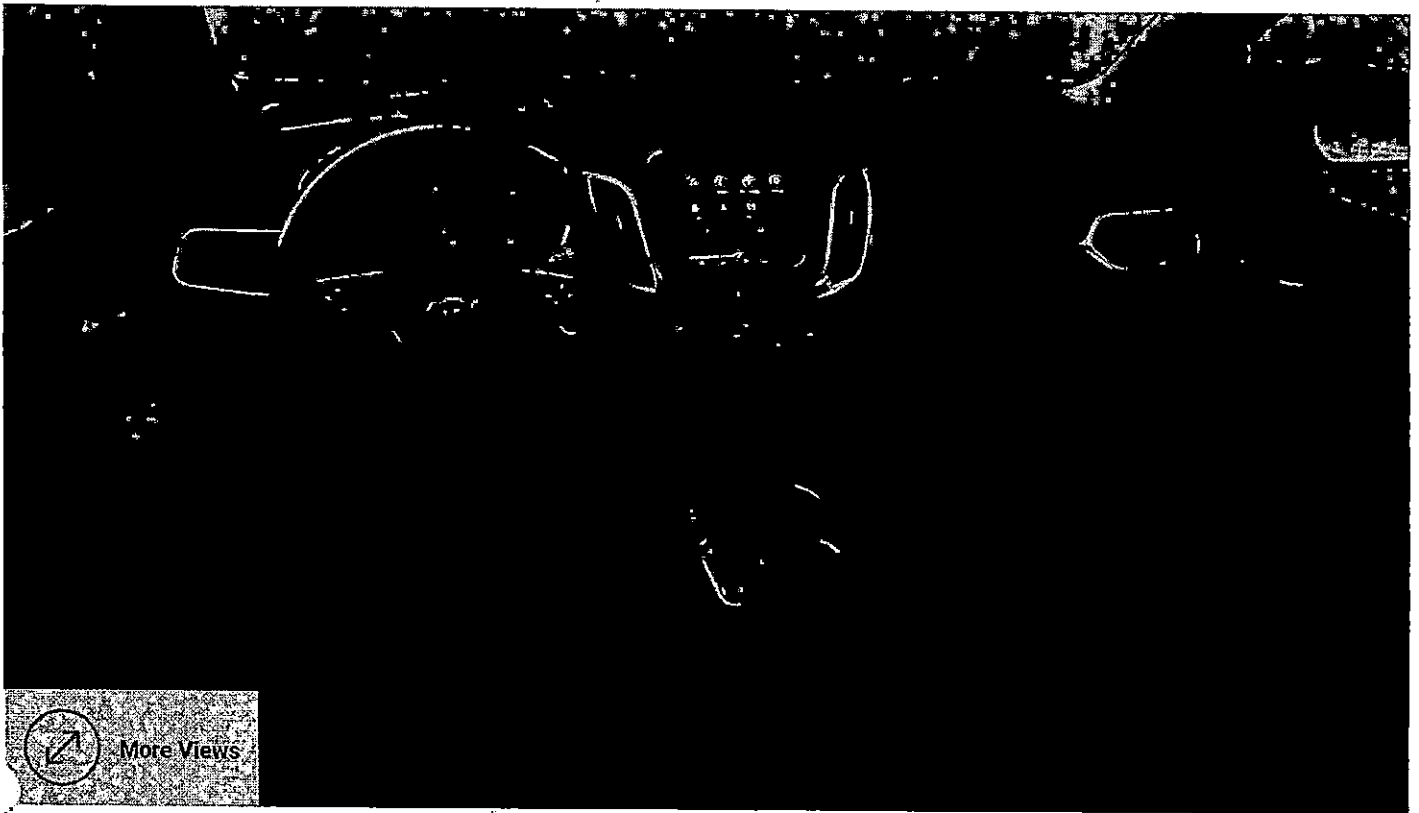

More Views



More Views

Your 2023 Equinox LS AWD

 [Send](#)

 [Save](#)

Net Price

\$29,595[†]

[Lease](#)

Estimated Lease Payment

\$445 Monthly for 36 months

\$445 due at signing (after all offers). No security deposit required. Ultra-low mileage Lease. Mileage charge of \$0.25/mile over 30,000 miles.

[Lease Details](#)



[Adjust Payments](#)

 Home Location 12020 [Edit](#)

Call and visit your local dealer for more information and purchase options.

Locate A Dealer

Ask your preferred dealer for a price quote on this vehicle.

Request A Quote

Estimate your trade-in value from the same Black Book® data dealers use to appraise vehicles.

Value Trade-In



SARATOGA COUNTY CAPITAL PLAN
PROJECT REQUEST FORM

Received:
Approved:
Project No.:
Priority No.:

In accordance with the Saratoga County Capital Budget Procedure, Department Heads may bring forth any Capital item and request review for inclusion in the County's Capital program. In general, any item costing more than \$25,000 and having a useful life of more than five years shall be reviewed. More information on criteria for inclusion in the Capital Plan is available on the County Intranet.

Department Heads shall submit this form to the County Administrator and outline the project goals and justification.

Department: **Emergency Services**

Division: **363 Fire Advisory Board**

Estimated Total Cost: **\$ 650,000.00**

Estimated Cost Breakdown by Category

Currently, there are long build out times. (Up to two years for certain apparatus) There is normally a partial payment equivalent to cost of chassis upon delivery of the chassis to the Manufacturer. The cost and breakdown will not be known until after unit is put out to bid and awarded.

NOTE: \$650,000.00 is a +/- guesstimate. Cost is based on economy, material cost, and market

Estimated Cost Breakdown by Year

Budget 2023 maybe out to 2024
Depending on contract and build time

Anticipated Source of Revenue

Budget

Project Description

The project is to replace the 2001 Spencer Manufacturing Hazardous Materials Response Unit on a Hendrickson Mobile Equipment (HME) Chassis



SARATOGA COUNTY CAPITAL PLAN
PROJECT REQUEST FORM

Purpose and Justification

This unit will replace a 21 year old unit. (Spencer Manufacturing unit with an HME Chassis.) There have been many safety and environmental changes in apparatus design since 2001 and the current expected build time is 1.5 to 2 years meaning the current unit will be approaching 24 years old.

Impact on County staff, space needs, and/or other operational impacts

No impact. This unit replaces HM 55-4 currently housed at Saratoga Springs Fire Station #2 with plans to move too Station #3 when finished.

Project Status

Basic Ideas have been discussed.

Status of Plans or Studies, if Necessary

Will be holding planing meetings with Saratoga Springs and County Haz Mat Chiefs. This will bring ideas together then meet to draw up the specification for bidding

Department Head: _____

Date: 28 July 2022

Long Range Capital Committee Action: _____

Date: _____

Board of Supervisors Action: _____

Date: _____

Note: Furnish as much of the information requested as is available at the time of preparation. Attach supporting data that will aid in evaluating the project.



SARATOGA COUNTY CAPITAL PLAN
PROJECT REQUEST FORM

Received:
Approved:
Project No.:
Priority No.:

In accordance with the Saratoga County Capital Budget Procedure, Department Heads may bring forth any Capital item and request review for inclusion in the County's Capital program. In general, any item costing more than \$25,000 and having a useful life of more than five years shall be reviewed. More information on criteria for inclusion in the Capital Plan is available on the County Intranet.

Department Heads shall submit this form to the County Administrator and outline the project goals and justification.

Department: Emergency Services

Division: 363 Fire Advisory Board

Estimated Total Cost: \$ 25,000.00

Estimated Cost Breakdown by Category

Concrete slab- \$5,000.00 (Estimated w/ Forbes.com formula)

Alternate: Black top

Building: 24' x 30' awaiting quote from one company but \$20,000.00 +/-

Estimated Cost Breakdown by Year

2023 \$25,000.

Anticipated Source of Revenue

Budget

Project Description

The project is for a pavilion type building (24' x 30') at the County Fire training Center. This will be for firefighters who are attending classes for relief from the sun between burns. The building would have power with misting fans during the rehab process.



SARATOGA COUNTY CAPITAL PLAN
PROJECT REQUEST FORM

Purpose and Justification

Difficult for students to stay cool during summer months. There are no trees on the Fire Training Center Grounds. With the building and misting fans, make it a good rehab area.

Impact on County staff, space needs, and/or other operational impacts

No Impact

Project Status

Research

Status of Plans or Studies, if Necessary

Same

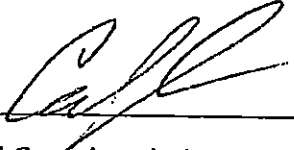
Department Head:  Date: 7/29/22

Long Range Capital Committee Action: _____ Date: _____

Board of Supervisors Action: _____ Date: _____

Note: Furnish as much of the information requested as is available at the time of preparation. Attach supporting data that will aid in evaluating the project.



SARATOGA COUNTY CAPITAL PLAN
PROJECT REQUEST FORM

Received:
Approved:
Project No.:
Priority No.:

In accordance with the Saratoga County Capital Budget Procedure, Department Heads may bring forth any Capital item and request review for inclusion in the County's Capital program. In general, any item costing more than \$25,000 and having a useful life of more than five years shall be reviewed. More information on criteria for inclusion in the Capital Plan is available on the County Intranet.

Department Heads shall submit this form to the County Administrator and outline the project goals and justification.

Department: **Emergency Services**

Division: **363 Fire Advisory Board**

Estimated Total Cost: **\$ 975,000.00**

Estimated Cost Breakdown by Category

Architectural, Engineering, site work/ studies- \$75,000.00

Building Construction- \$900,000.00

Estimated Cost Breakdown by Year

2023- Architectural, Site Work/ Studies \$75,000.00

2023/ 24- Building Construction \$825,000.00

NOTE: Costs are guesstimates and won't really know until bid. Industry is very busy currently which may or may not delay.

Anticipated Source of Revenue

Working on a \$500,000.00 DASNY Grant but have been waiting for over 5 years and status is uncertain.

Project Description

Construction of a new burn building for the County Fire Training Center.



SARATOGA COUNTY CAPITAL PLAN
PROJECT REQUEST FORM

Purpose and Justification

The current building was built March 2006 and is feeling its age. Repair work is more constant and costly. This building is used constantly for Fire Department Training and Fire Training Classes. Not having this building would cause travel and reliance on other county facilities IF available.

Impact on County staff, space needs, and/or other operational impacts

No impact. Area at the Fire Training Center is available

Project Status

Some site work is done. Have a planing committee together consisting of State Fire Instructors. Have met a few times to discuss what to incorporate in the building to suit training needs. Have met with a few vendors to discuss various building designs

Status of Plans or Studies, if Necessary

N/A

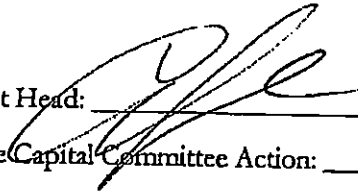
Department Head:  Date: 7/29/22
Long Range Capital Committee Action: _____ Date: _____
Board of Supervisors Action: _____ Date: _____

Note: Furnish as much of the information requested as is available at the time of preparation. Attach supporting data that will aid in evaluating the project.



SARATOGA COUNTY CAPITAL PLAN
PROJECT REQUEST FORM

Received:
Approved:
Project No.:
Priority No.:

In accordance with the Saratoga County Capital Budget Procedure, Department Heads may bring forth any Capital item and request review for inclusion in the County's Capital program. In general, any item costing more than \$25,000 and having a useful life of more than five years shall be reviewed. More information on criteria for inclusion in the Capital Plan is available on the County Intranet.

Department Heads shall submit this form to the County Administrator and outline the project goals and justification.

Department: **Buildings and Grounds**

Division: Airport

Estimated Total Cost: \$ 31,000,000.00

Estimated Cost Breakdown by Category

Design and Inspection: \$3,500,000

Construction: \$27,500,000

Estimated Cost Breakdown by Year

2023 - \$20,000,000 (State Funds)

2024 - \$7,000,000 (State Funds), \$3,065,000 (Local Funds), \$935,000 (Federal Funds)

Anticipated Source of Revenue

\$27,000,000 State Grant, \$935,000 Federal Funds

Project Description

New Fixed Base Operator Terminal Building project consisting of the following:

1. Demolition of existing Hangar 1.
2. Redevelopment of the entrance corridor and existing parking area.
3. Construction of a new fixed base operator terminal building to include new waiting areas; concessionaire tenant spaces; rental car lease space; advertisement display lease opportunities; conference room space; weather information access station; pilot lounge area; and connected 39,000 square-foot hangar space.
4. Installation of solar panel array on hangar portion of new terminal building.
5. Rehabilitation of the apron connecting to new terminal building



SARATOGA COUNTY CAPITAL PLAN
PROJECT REQUEST FORM

Purpose and Justification

Design and construction of airport terminal

Impact on County staff, space needs, and/or other operational impacts

DPW will have oversight of project management and all contracts. Position of Airport Manager included in 2023 budget request to assist facilitation and execution of this project.

Project Status

Award Granted. Project in planning phase.

Status of Plans or Studies, if Necessary

Conceptual design

Department Head:  Date: 09/27/2022
Long Range Capital Committee Action: _____ Date: _____
Board of Supervisors Action: _____ Date: _____

Note: Furnish as much of the information requested as is available at the time of preparation. Attach supporting data that will aid in evaluating the project.



Department of Transportation

KATHY HOCHUL
Governor

MARIE THERESE DOMINGUEZ
Commissioner

September 15, 2022

Mr. Thomas Speziale
Deputy Commissioner of Public Works
3654 Galway Road
Ballston Spa, New York 12020

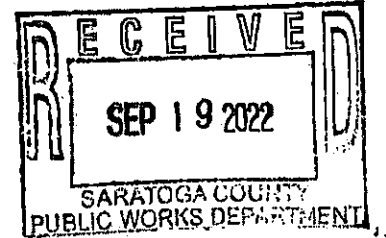

Dear Mr. Speziale:

I would like to personally congratulate you and your staff at the Saratoga County Airport for your successful application for funding under Governor Hochul's Upstate Airport Economic Development and Revitalization initiative.

As noted by Governor Hochul, the goals of this initiative are to promote, revitalize and rapidly accelerate investments in Upstate airports to create jobs and enhance regional economic competitiveness. To realize the regional benefits of this significant State investment in Upstate airports, the New York State Department of Transportation (NYSDOT) will provide direct staff and consultant support to aggressively streamline the project design, procurement and delivery schedules to meet the mandatory October 2024 project completion deadline.

Failure to meet the mandatory project completion deadline of October 2024 and/or the conditions outlined below may result in the loss of direct State funding for this project. To ensure adherence to project delivery schedules, the Airport will be required to:

- Submit all proposals related to the design and scheduling for each item identified in Schedule B of the project funding agreement, sent under separate cover, to NYSDOT; NYSDOT will review and approve the information submitted prior to authorizing the Airport to procure or provide services, materials or equipment related to that Schedule B item.
- Submit the names of all proposed contractor, consultant, sub-contractor, or sub-consultant to be retained in connection with the New FBO Terminal Building Project to NYSDOT; NYSDOT will review and authorize use of the proposed entity prior to that entity commencing work on the project.
- Comply with all aviation industry standards and regulations such as those of the Federal Aviation Administration (FAA), Transportation Security Administration (TSA), U.S. Customs and Border Protection (CBP) and other appropriate entities, as needed to perform the work.
- Comply with State and/or federal environmental and cultural resource processes; NYSDOT will review documents to ensure completeness.
- Submit all contract documents, including stringent incentive/disincentive scheduling provisions, to NYSDOT for prior review and approval.

- Demonstrate the availability of local funds required to undertake and complete the project.

During this review and approval process, the Department reserves the right to recommend changes to any of the plans or specifications developed to implement the project phases authorized under this grant award. It is imperative that you, as the project sponsor, incorporate innovative construction methods to deliver this project expeditiously. In the coming weeks, you and your staff will receive an invitation to an Upstate Airport Summit to further discuss the implementation procedures associated with delivering this project through the Governor's initiative.

Thank you in advance for your collaboration on delivering the New FBO Terminal Building Project on budget and schedule. Should you have any questions regarding this letter, please contact Nicolas Choubah at (518) 457-4430 or nick.choubah@dot.ny.gov.

Sincerely,



Marie Therese Dominguez
Commissioner